

# ADP

## SECTION

### AUTOMATIC DRIVE POSITIONER

A  
B  
C  
D  
E  
F  
G  
H  
I  
ADP  
K  
L  
M  
N  
O  
P

## CONTENTS

<b>PRECAUTION</b> .....	4	LINKING KEY FOB TO THE METER DISPLAY :	
<b>PRECAUTIONS</b> .....	4	System Description .....	21
Precaution for Supplemental Restraint System (SRS) "AIR BAG" and "SEAT BELT PRE-TENSIONER" .....	4	Fail Safe .....	22
Precaution for Work .....	4	<b>DIAGNOSIS SYSTEM (DRIVER SEAT CONTROL UNIT)</b> .....	24
<b>PREPARATION</b> .....	5	CONSULT Function (AUTO DRIVE POS.) .....	24
<b>PREPARATION</b> .....	5	<b>ECU DIAGNOSIS INFORMATION</b> .....	27
Special Service Tools .....	5	<b>DRIVER SEAT CONTROL UNIT</b> .....	27
<b>SYSTEM DESCRIPTION</b> .....	6	Reference Value .....	27
<b>COMPONENT PARTS</b> .....	6	Fail Safe .....	32
Component Parts Location .....	6	DTC Index .....	32
Automatic Drive Positioner Control Unit .....	9	<b>AUTOMATIC DRIVE POSITIONER CONTROL UNIT</b> .....	34
Driver Seat Control Unit .....	9	Reference Value .....	34
Seat Memory Switch .....	9	<b>BCM (BODY CONTROL MODULE)</b> .....	37
ADP Steering Switch .....	10	List of ECU Reference .....	37
Tilt & Telescopic Motor .....	10	<b>WIRING DIAGRAM</b> .....	38
<b>SYSTEM</b> .....	12	<b>AUTOMATIC DRIVE POSITIONER SYSTEM</b> ...	38
<b>AUTOMATIC DRIVE POSITIONER SYSTEM</b> .....	12	Wiring Diagram .....	38
AUTOMATIC DRIVE POSITIONER SYSTEM :		<b>BASIC INSPECTION</b> .....	50
System Description .....	12	<b>DIAGNOSIS AND REPAIR WORK FLOW</b> .....	50
<b>MANUAL FUNCTION</b> .....	13	Work Flow .....	50
MANUAL FUNCTION : System Description .....	14	<b>INSPECTION AND ADJUSTMENT</b> .....	53
<b>MEMORY FUNCTION</b> .....	15	<b>ADDITIONAL SERVICE WHEN REMOVING BATTERY NEGATIVE TERMINAL</b> .....	53
MEMORY FUNCTION : System Description .....	16	ADDITIONAL SERVICE WHEN REMOVING BATTERY NEGATIVE TERMINAL : Work Procedure .....	53
<b>EXIT ASSIST FUNCTION</b> .....	17	<b>ADDITIONAL SERVICE WHEN REPLACING CONTROL UNIT</b> .....	53
EXIT ASSIST FUNCTION : System Description ....	18		
<b>ENTRY ASSIST FUNCTION</b> .....	19		
ENTRY ASSIST FUNCTION : System Description .....	19		
<b>LINKING KEY FOB TO THE METER DISPLAY</b> .....	20		

ADDITIONAL SERVICE WHEN REPLACING CONTROL UNIT : Description .....	53	<b>AUTOMATIC DRIVE POSITIONER CONTROL UNIT .....</b>	<b>70</b>
ADDITIONAL SERVICE WHEN REPLACING CONTROL UNIT : Work Procedure .....	53	AUTOMATIC DRIVE POSITIONER CONTROL UNIT : Diagnosis Procedure .....	70
<b>SYSTEM INITIALIZATION .....</b>	<b>54</b>	AUTOMATIC DRIVE POSITIONER CONTROL UNIT : Special Repair Requirement .....	71
SYSTEM INITIALIZATION : Description .....	54	<b>SLIDING SWITCH .....</b>	<b>72</b>
SYSTEM INITIALIZATION : Work Procedure .....	54	Component Function Check .....	72
<b>MEMORY STORING .....</b>	<b>54</b>	Diagnosis Procedure .....	72
MEMORY STORING : Description .....	54	Component Inspection .....	73
MEMORY STORING : Work Procedure .....	54	<b>RECLINING SWITCH .....</b>	<b>74</b>
<b>LINKING KEY FOB TO THE METER DISPLAY .....</b>	<b>55</b>	Component Function Check .....	74
LINKING KEY FOB TO THE METER DISPLAY : Description .....	55	Diagnosis Procedure .....	74
LINKING KEY FOB TO THE METER DISPLAY : Work Procedure .....	55	Component Inspection .....	75
<b>SYSTEM SETTING .....</b>	<b>56</b>	<b>LIFTING SWITCH (FRONT) .....</b>	<b>76</b>
SYSTEM SETTING : Description .....	56	Component Function Check .....	76
SYSTEM SETTING : Work Procedure .....	56	Diagnosis Procedure .....	76
<b>DTC/CIRCUIT DIAGNOSIS .....</b>	<b>58</b>	Component Inspection .....	77
<b>U1000 CAN COMM CIRCUIT .....</b>	<b>58</b>	<b>LIFTING SWITCH (REAR) .....</b>	<b>78</b>
DTC Description .....	58	Component Function Check .....	78
Diagnosis Procedure .....	58	Diagnosis Procedure .....	78
<b>U1010 CONTROL UNIT (CAN) .....</b>	<b>59</b>	Component Inspection .....	79
DTC Description .....	59	<b>TILT SWITCH .....</b>	<b>80</b>
Diagnosis Procedure .....	59	Component Function Check .....	80
<b>B2112 SLIDING MOTOR .....</b>	<b>60</b>	Diagnosis Procedure .....	80
DTC Description .....	60	Component Inspection .....	81
Diagnosis Procedure .....	60	<b>TELESCOPIC SWITCH .....</b>	<b>82</b>
<b>B2113 RECLINING MOTOR .....</b>	<b>62</b>	Component Function Check .....	82
DTC Description .....	62	Diagnosis Procedure .....	82
Diagnosis Procedure .....	62	Component Inspection .....	83
<b>B2116 TILT MOTOR .....</b>	<b>64</b>	<b>SEAT MEMORY SWITCH .....</b>	<b>84</b>
DTC Description .....	64	Component Function Check .....	84
Diagnosis Procedure .....	64	Diagnosis Procedure .....	84
<b>B2128 UART COMMUNICATION LINE .....</b>	<b>66</b>	Component Inspection .....	85
DTC Description .....	66	<b>DOOR MIRROR REMOTE CONTROL SWITCH .....</b>	<b>87</b>
Diagnosis Procedure .....	66	<b>SELECT SWITCH .....</b>	<b>87</b>
<b>B2130 EEPROM .....</b>	<b>68</b>	SELECT SWITCH : Component Function Check .....	87
DTC Description .....	68	SELECT SWITCH : Diagnosis Procedure .....	87
Diagnosis Procedure .....	68	SELECT SWITCH : Component Inspection .....	88
<b>POWER SUPPLY AND GROUND CIRCUIT ....</b>	<b>69</b>	<b>MIRROR SWITCH .....</b>	<b>88</b>
<b>BCM .....</b>	<b>69</b>	MIRROR SWITCH : Component Function Check .....	89
BCM : Diagnosis Procedure .....	69	MIRROR SWITCH : Diagnosis Procedure .....	89
<b>DRIVER SEAT CONTROL UNIT .....</b>	<b>69</b>	MIRROR SWITCH : Component Inspection .....	90
DRIVER SEAT CONTROL UNIT : Diagnosis Procedure .....	69	<b>POWER SEAT SWITCH GROUND CIRCUIT ...</b>	<b>92</b>
DRIVER SEAT CONTROL UNIT : Special Repair Requirement .....	70	Diagnosis Procedure .....	92
		<b>TILT &amp; TELESCOPIC SWITCH GROUND CIRCUIT .....</b>	<b>93</b>
		Diagnosis Procedure .....	93

<b>SLIDING SENSOR</b> .....	<b>94</b>	<b>LIFTING MOTOR (REAR)</b> .....	<b>117</b>	
Component Function Check .....	94	Component Function Check .....	117	A
Diagnosis Procedure .....	94	Diagnosis Procedure .....	117	
<b>RECLINING SENSOR</b> .....	<b>96</b>	<b>TILT MOTOR</b> .....	<b>119</b>	B
Component Function Check .....	96	Component Function Check .....	119	
Diagnosis Procedure .....	96	Diagnosis Procedure .....	119	
<b>LIFTING SENSOR (FRONT)</b> .....	<b>98</b>	<b>TELESCOPIC MOTOR</b> .....	<b>121</b>	C
Component Function Check .....	98	Component Function Check .....	121	
Diagnosis Procedure .....	98	Diagnosis Procedure .....	121	
<b>LIFTING SENSOR (REAR)</b> .....	<b>101</b>	<b>DOOR MIRROR MOTOR</b> .....	<b>123</b>	D
Component Function Check .....	101	Component Function Check .....	123	
Diagnosis Procedure .....	101	Diagnosis Procedure .....	123	
		Component Inspection .....	125	E
<b>TILT SENSOR</b> .....	<b>103</b>	<b>SEAT MEMORY INDICATOR</b> .....	<b>126</b>	F
Component Function Check .....	103	Component Function Check .....	126	
Diagnosis Procedure .....	103	Diagnosis Procedure .....	126	
<b>TELESCOPIC SENSOR</b> .....	<b>105</b>	Component Inspection .....	127	
Component Function Check .....	105	<b>SYMPTOM DIAGNOSIS</b> .....	<b>128</b>	G
Diagnosis Procedure .....	105	<b>ADP SYSTEM SYMPTOMS</b> .....	<b>128</b>	
<b>MIRROR SENSOR</b> .....	<b>107</b>	Symptom Table .....	128	H
<b>DRIVER SIDE</b> .....	<b>107</b>	<b>NORMAL OPERATING CONDITION</b> .....	<b>129</b>	I
DRIVER SIDE : Component Function Check .....	107	Description .....	129	
DRIVER SIDE : Diagnosis Procedure .....	107	<b>REMOVAL AND INSTALLATION</b> .....	<b>130</b>	
<b>PASSENGER SIDE</b> .....	<b>108</b>	<b>DRIVER SEAT CONTROL UNIT</b> .....	<b>130</b>	ADP
PASSENGER SIDE :		Removal and Installation .....	130	
Component Function Check .....	108	<b>AUTOMATIC DRIVE POSITIONER CON-</b>		
PASSENGER SIDE : Diagnosis Procedure .....	109	<b>TROL UNIT</b> .....	<b>131</b>	K
<b>SLIDING MOTOR</b> .....	<b>111</b>	Removal and Installation .....	131	
Component Function Check .....	111	<b>SEAT MEMORY SWITCH</b> .....	<b>132</b>	L
Diagnosis Procedure .....	111	Removal and Installation .....	132	
<b>RECLINING MOTOR</b> .....	<b>113</b>	<b>POWER SEAT SWITCH</b> .....	<b>133</b>	M
Component Function Check .....	113	Removal and Installation .....	133	
Diagnosis Procedure .....	113	<b>ADP STEERING SWITCH</b> .....	<b>134</b>	N
<b>LIFTING MOTOR (FRONT)</b> .....	<b>115</b>	Removal and Installation .....	134	
Component Function Check .....	115			O
Diagnosis Procedure .....	115			P

# PRECAUTIONS

< PRECAUTION >

## PRECAUTION

### PRECAUTIONS

#### Precaution for Supplemental Restraint System (SRS) "AIR BAG" and "SEAT BELT PRE-TENSIONER"

INFOID:000000012232340

The Supplemental Restraint System such as "AIR BAG" and "SEAT BELT PRE-TENSIONER", used along with a front seat belt, helps to reduce the risk or severity of injury to the driver and front passenger for certain types of collision. Information necessary to service the system safely is included in the SR and SB section of this Service Manual.

#### **WARNING:**

- To avoid rendering the SRS inoperative, which could increase the risk of personal injury or death in the event of a collision which would result in air bag inflation, all maintenance must be performed by an authorized NISSAN/INFINITI dealer.
- Improper maintenance, including incorrect removal and installation of the SRS, can lead to personal injury caused by unintentional activation of the system. For removal of Spiral Cable and Air Bag Module, see the SR section.
- Do not use electrical test equipment on any circuit related to the SRS unless instructed to in this Service Manual. SRS wiring harnesses can be identified by yellow and/or orange harnesses or harness connectors.

#### PRECAUTIONS WHEN USING POWER TOOLS (AIR OR ELECTRIC) AND HAMMERS

#### **WARNING:**

- When working near the Airbag Diagnosis Sensor Unit or other Airbag System sensors with the Ignition ON or engine running, DO NOT use air or electric power tools or strike near the sensor(s) with a hammer. Heavy vibration could activate the sensor(s) and deploy the air bag(s), possibly causing serious injury.
- When using air or electric power tools or hammers, always switch the Ignition OFF, disconnect the battery and wait at least three minutes before performing any service.

#### Precaution for Work

INFOID:000000012232341

- When removing or disassembling each component, be careful not to damage or deform it. If a component may be subject to interference, be sure to protect it with a shop cloth.
- When removing (disengaging) components with a screwdriver or similar tool, be sure to wrap the component with a shop cloth or vinyl tape to protect it.
- Protect the removed parts with a shop cloth and prevent them from being dropped.
- Replace a deformed or damaged clip.
- If a part is specified as a non-reusable part, always replace it with a new one.
- Be sure to tighten bolts and nuts securely to the specified torque.
- After installation is complete, be sure to check that each part works properly.
- Follow the steps below to clean components:
  - Water soluble dirt:
    - Dip a soft cloth into lukewarm water, wring the water out of the cloth and wipe the dirty area.
    - Then rub with a soft, dry cloth.
  - Oily dirt:
    - Dip a soft cloth into lukewarm water with mild detergent (concentration: within 2 to 3%) and wipe the dirty area.
    - Then dip a cloth into fresh water, wring the water out of the cloth and wipe the detergent off.
    - Then rub with a soft, dry cloth.
  - Do not use organic solvent such as thinner, benzene, alcohol or gasoline.
  - For genuine leather seats, use a genuine leather seat cleaner.

# PREPARATION

< PREPARATION >

## PREPARATION

### PREPARATION

#### Special Service Tools

INFOID:0000000012233583

The actual shape of the tools may differ from those illustrated here.

Tool number (TechMate No.) Tool name	Description
— (J-46534) Trim Tool Set	Removing trim components

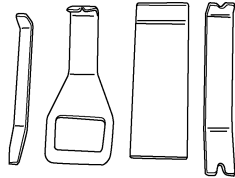

AWJIA0483ZZ

A  
B  
C  
D  
E  
F  
G  
H  
I

ADP

K  
L  
M  
N  
O  
P

# COMPONENT PARTS

< SYSTEM DESCRIPTION >

## SYSTEM DESCRIPTION

### COMPONENT PARTS

#### Component Parts Location

INFOID:000000012246450

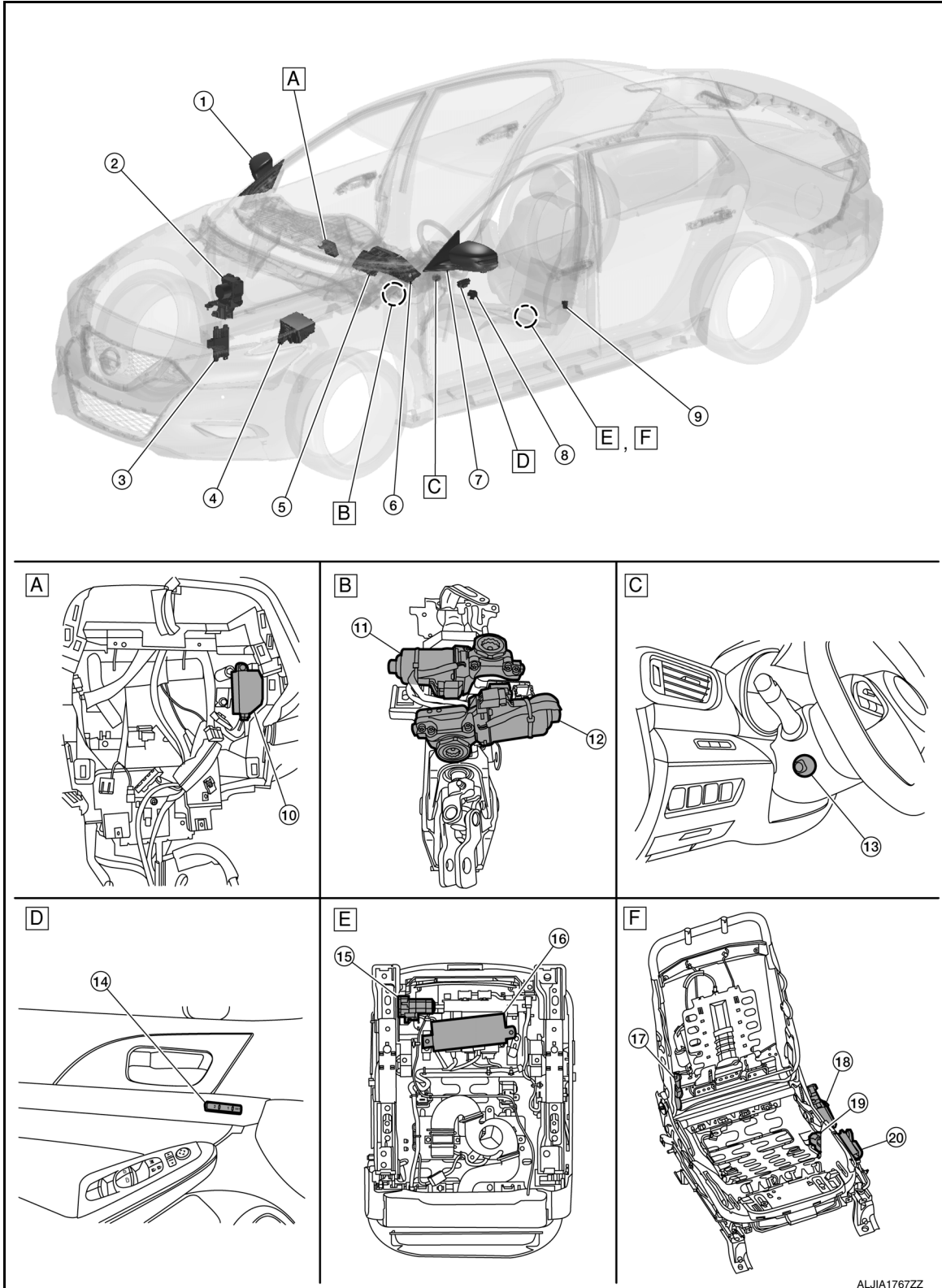

ALJIA1767ZZ

# COMPONENT PARTS

## < SYSTEM DESCRIPTION >

- A. LH side of instrument panel (view with instrument panel removed)    B. Steering column (view with steering column removed)    C. Left hand side of steering column
- D. View of left front door finisher    E. Driver seat bottom (view with seat re-moved)    F. LH side of driver seat (view with seat disassembled)

A  
B  
C  
D  
E  
F  
G  
H  
I  
ADP  
K  
L  
M  
N  
O  
P

No.	Component		Function
1.	Door mirror (LH)	Door mirror motor	<ul style="list-style-type: none"> <li>Makes mirror face operate from side to side and up and down with the electric power that automatic drive positioner control unit supplies.</li> <li>Refer to <a href="#">MIR-4, "Component Parts Location"</a> for detailed installation location.</li> </ul>
		Mirror sensor	<ul style="list-style-type: none"> <li>Mirror sensor is installed to door mirror.</li> <li>The resistance of 2 sensors (horizontal and vertical) is changed when door mirror is operated.</li> <li>Automatic drive positioner control unit calculates door mirror position according to the change of the voltage of 2 sensor input terminals.</li> <li>Refer to <a href="#">MIR-4, "Component Parts Location"</a> for detailed installation location.</li> </ul>
2.	ABS actuator and electric unit (control unit)		<ul style="list-style-type: none"> <li>Transmits the vehicle speed signal to driver seat control unit via CAN communication.</li> <li>Refer to <a href="#">BRC-10, "Component Parts Location"</a> for detailed installation location.</li> </ul>
3.	TCM		<ul style="list-style-type: none"> <li>Refer to <a href="#">TM-12, "CVT CONTROL SYSTEM : Component Parts Location"</a>.</li> </ul>
4.	IPDM E/R		<ul style="list-style-type: none"> <li>Transmits the detention switch signal to driver seat control unit via CAN communication.</li> <li>Refer to <a href="#">PCS-5, "Component Parts Location"</a> for detailed installation location.</li> </ul>
5.	BCM		<ul style="list-style-type: none"> <li>Recognizes the following statuses and transmits them to driver seat control unit via CAN communication:</li> <li>Handle position: LHD</li> <li>Driver door: OPEN/CLOSE</li> <li>Ignition switch position: ACC/ON</li> <li>Door lock: UNLOCK (with Intelligent Key or driver side door request switch operation)</li> <li>Key ID</li> <li>Starter: CRANKING/OTHER</li> <li>Refer to <a href="#">BCS-5, "BODY CONTROL SYSTEM : Component Parts Location"</a> for detailed installation location.</li> </ul>
6.	Combination meter		<ul style="list-style-type: none"> <li>Transmits the vehicle speed signal to driver seat control unit via CAN communication.</li> </ul>
7.	Door mirror (RH)	Door mirror motor	<ul style="list-style-type: none"> <li>Makes mirror face operate from side to side and up and down with the electric power that automatic drive positioner control unit supplies.</li> <li>Refer to <a href="#">MIR-4, "Component Parts Location"</a> for detailed installation location.</li> </ul>
		Mirror sensor	<ul style="list-style-type: none"> <li>Mirror sensor is installed to door mirror.</li> <li>The resistance of 2 sensors (horizontal and vertical) is changed when door mirror is operated.</li> <li>Automatic drive positioner control unit calculates door mirror position according to the change of the voltage of 2 sensor input terminals.</li> <li>Refer to <a href="#">MIR-4, "Component Parts Location"</a> for detailed installation location.</li> </ul>

# COMPONENT PARTS

## < SYSTEM DESCRIPTION >

No.	Component	Function
8.	Door mirror remote control switch	Mirror switch
	Door mirror remote control switch	Select switch
9.	Front door switch (LH)	Front door switch (LH)
10.	Automatic drive positioner control unit	
11.	Tilt motor	Tilt motor
	Tilt motor	Tilt sensor
12.	Telescopic motor	Tilt motor
	Telescopic motor	Tilt sensor
13.	ADP steering switch	
14.	Seat memory switch	
15.	Sliding motor LH	Sliding motor
	Sliding motor LH	Sliding sensor
16.	Driver seat control unit	
17.	Reclining motor LH	Reclining motor
	Reclining motor LH	Reclining sensor
18.	Lifting motor LH (rear)	Lifting motor
	Lifting motor LH (rear)	Lifting sensor



# COMPONENT PARTS

## < SYSTEM DESCRIPTION >

No.	Component		Function
19.	Lifting motor LH (front)	Lifting motor	<ul style="list-style-type: none"> <li>Lifting motor (front) is installed to seat frame assembly (driver side).</li> <li>Lifting motor is activated with driver seat control unit.</li> <li>Lifting motor (front) is moved upward/downward by changing the rotation direction of lifting motor (front).</li> </ul>
		Lifting sensor	<ul style="list-style-type: none"> <li>Lifting sensor (front) is installed in lifting motor (front).</li> <li>When lifting motor (front) operates, pulse signal is transmitted to driver seat control unit from lifting sensor. Driver seat control unit counts the pulse and calculates the lift position (front) of the seat.</li> </ul>
20.	Power seat switch LH	Sliding switch	<ul style="list-style-type: none"> <li>Sliding switch is equipped to power seat switch on seat cushion side surface.</li> <li>The operation signal is input to driver seat control unit when sliding switch is operated.</li> </ul>
		Reclining switch	<ul style="list-style-type: none"> <li>Reclining switch is equipped to power seat switch on seat cushion side surface.</li> <li>The operation signal is input to driver seat control unit when reclining switch is operated.</li> </ul>
		Lifting switch (front)	<ul style="list-style-type: none"> <li>Lifting switch (front) is equipped to power seat switch on seat cushion side surface.</li> <li>The operation signal is input to driver seat control unit when lifting switch (front) is operated.</li> </ul>
		Lifting switch (rear)	<ul style="list-style-type: none"> <li>Lifting switch (rear) is equipped to power seat switch on seat cushion side surface.</li> <li>The operation signal is input to driver seat control unit when lifting switch (rear) is operated.</li> </ul>

### Automatic Drive Positioner Control Unit

INFOID:0000000012246451

- It communicates with driver seat control unit via UART communication.
- Performs various controls with the instructions of driver seat control unit.
- Performs the controls of tilt & telescopic and door mirror.
- Operates steering column and door mirror with the signal from the driver seat control.

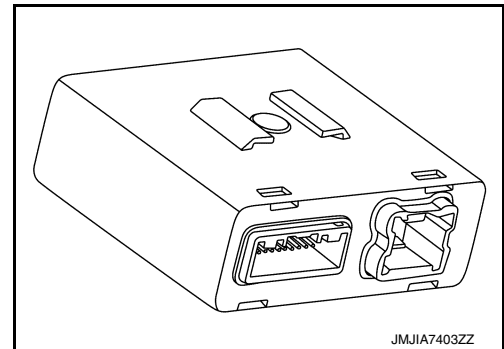

ADP

### Driver Seat Control Unit

INFOID:0000000012246452

- Main unit of automatic drive positioner system.
- It is connected to the CAN communication system.
- It communicates with automatic drive positioner control unit via UART communication.
- The address of each part is recorded.
- Operates each motor of seat to the registered position.
- Requests the operation of steering column and door mirror to automatic drive positioner control unit.
- Performs the control of seat memory switch.
- Operates the specific seat motor with the signal from power seat switch.

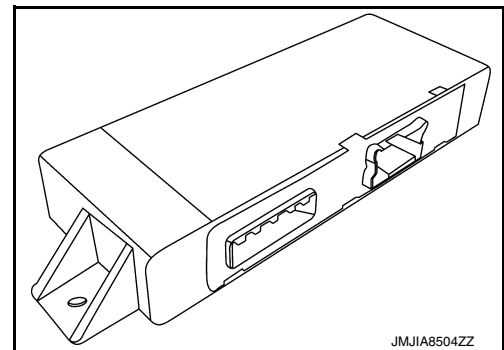

### Seat Memory Switch

INFOID:0000000012246453

### SET SWITCH

# COMPONENT PARTS

## < SYSTEM DESCRIPTION >

It is used for registration and setting change of driving position.

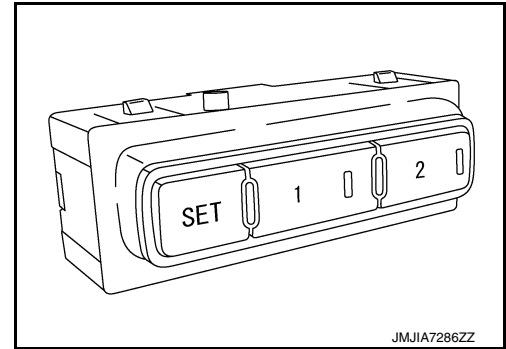

JMJIA7286ZZ

### SEAT MEMORY SWITCH

- The maximum 2 driving positions can be registered by memory switch 1 and 2.
- Driving position is set to the registered driving position when memory switch is pressed while operation conditions are satisfied.

### SEAT MEMORY INDICATOR

Memory indicator indicates the status of auto driving position system by turning ON or blinking.

### ADP Steering Switch

INFOID:000000012246454

- ADP steering switch is equipped to steering column.
- The operation signal is input to automatic drive positioner control unit when switch is operated.

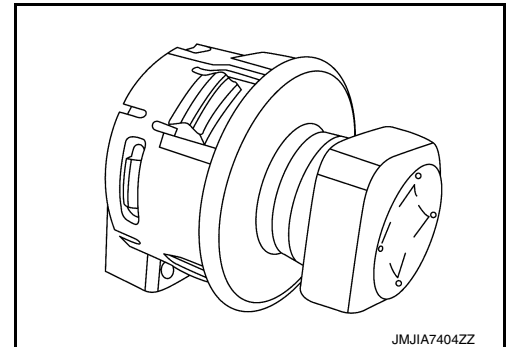

JMJIA7404ZZ

### Tilt & Telescopic Motor

INFOID:000000012246455

#### TILT MOTOR

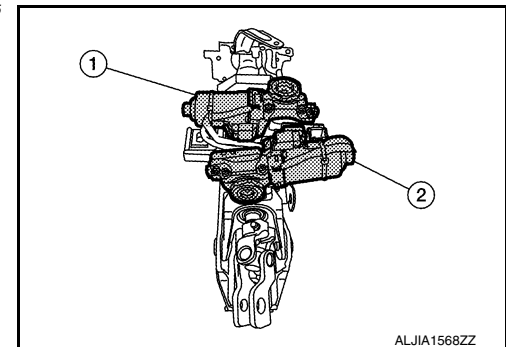

ALJIA1568ZZ

- Tilt motor (1) is installed to steering column assembly.
- Tilt motor is activated with automatic drive positioner control unit.
- Steering column is tilted upward/downward by changing the rotation direction of tilt motor.

#### TILT SENSOR

- Tilt sensor is integrated in tilt motor (1).
- The resistance of tilt sensor is changed according to the up/down position of steering column.
- The terminal voltage of automatic drive positioner control unit will be changed according to a change of tilt sensor resistance.
- Automatic drive positioner control unit calculates the tilt position from the voltage.

#### TELESCOPIC MOTOR

- Telescopic motor (2) is installed to steering column assembly.
- Telescopic motor is activated with automatic drive positioner control unit.
- Compresses steering column by changing the rotation direction of telescopic motor.

#### TELESCOPIC SENSOR

## COMPONENT PARTS

### < SYSTEM DESCRIPTION >

---

- Telescopic sensor is integrated in telescopic motor (2).
- The resistance of telescopic sensor is changed according to the forward/backward position of steering column.
- The terminal voltage of automatic drive positioner control unit will be changed according to a change of telescopic sensor resistance.
- Automatic drive positioner control unit calculates the telescopic position from the voltage.

A

B

C

D

E

F

G

H

I

ADP

K

L

M

N

O

P

# SYSTEM

< SYSTEM DESCRIPTION >

## SYSTEM

### AUTOMATIC DRIVE POSITIONER SYSTEM

### AUTOMATIC DRIVE POSITIONER SYSTEM : System Description

INFOID:000000012246456

### SYSTEM DIAGRAM

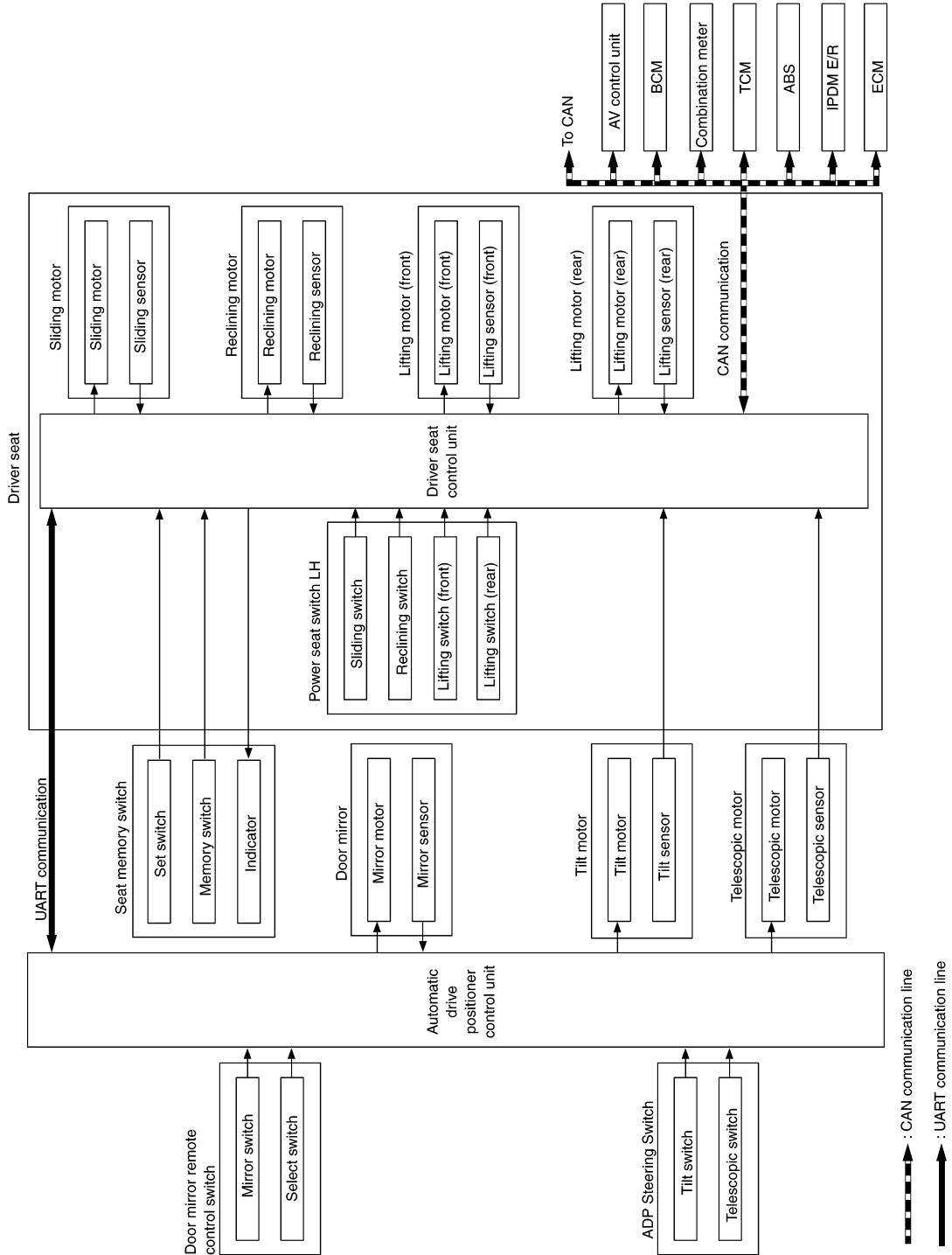

AWJIA1884GB

### OUTLINE

# SYSTEM

## < SYSTEM DESCRIPTION >

The system automatically moves the driver seat, steering column and door mirror position by the driver seat control unit and the automatic drive positioner control unit. The driver seat control unit corresponds with the automatic drive positioner control unit by UART communication.

Function		Description
Manual function		The driving position (seat, steering column and door mirror position) can be adjusted by using the power seat switch, ADP steering switch or door mirror remote control switch.
Memory function		The seat, steering column and door mirror move to the stored driving position by pressing seat memory switch (1 or 2).
Entry/Exit assist function	Exit	On exit, the seat moves backward and the steering column moves upward.
	Entry	On entry, the seat and steering column return from exiting position to the previous driving position.
Linking key fob to meter display		Performs memory operation, exiting operation and entry operation by Intelligent Key unlock operation or driver side door request switch unlock operation.

### NOTE:

The lumbar support system is controlled independently with no link to the automatic drive positioner system.

## MANUAL FUNCTION

A  
B  
C  
D  
E  
F  
G  
H  
I  
K  
L  
M  
N  
O  
P

ADP

# SYSTEM

< SYSTEM DESCRIPTION >

## MANUAL FUNCTION : System Description

INFOID:000000012246457

### SYSTEM DIAGRAM

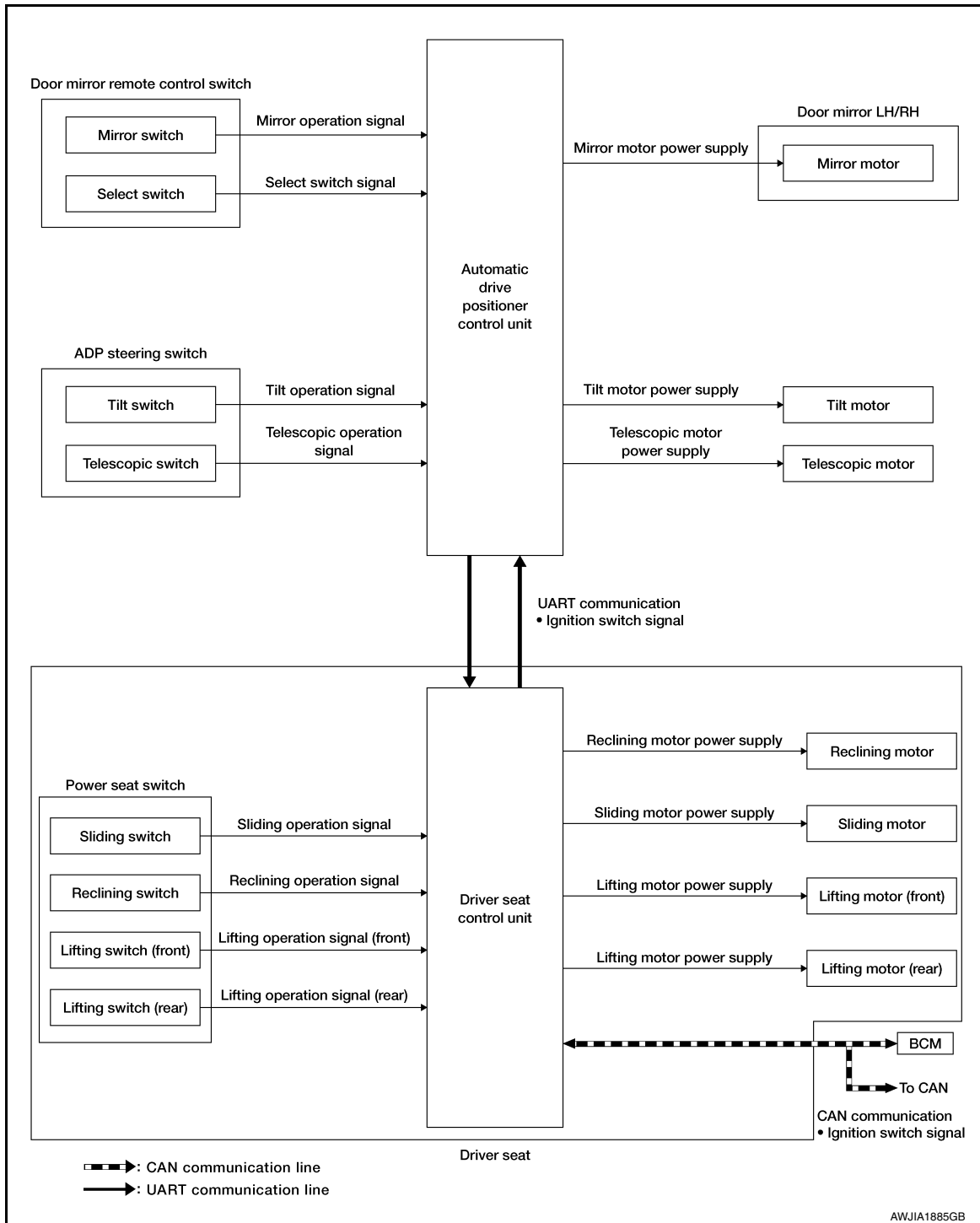

### DESCRIPTION

The driving position (seat, steering column and door mirror position) can be adjusted manually with power seat switch, ADP steering switch and door mirror remote control switch.

### Operation procedure

1. Turn ignition switch ON/ACC.
2. Operate power seat switch, ADP steering switch or door mirror remote control switch.
3. The driver seat, steering column or door mirror operates according to the operation of each switch.

### DETAIL FLOW

# SYSTEM

## < SYSTEM DESCRIPTION >

### Seat

Order	Input	Output	Control unit condition
1	Power seat switch (sliding, lifting, reclining)	—	The power seat switch signal is inputted to the driver seat control unit when the power seat switch is operated.
2	—	Motors (sliding LH, lifting LH, reclining LH)	The driver seat control unit outputs signals to each motor according to the power seat switch input signal.

### Tilt and Telescopic

Order	Input	Output	Control unit condition
1	ADP steering switch	—	The ADP steering switch signal is input to the automatic drive positioner control unit when the ADP steering switch is operated.
2	—	Motors (tilt, telescopic)	The automatic drive positioner control unit actuates the motors according to the operation of the ADP steering switch signal.
3	Sensors (tilt, telescopic)	—	The automatic drive positioner control unit recognizes any operation limit of each actuator via each sensor and will not operate the motors anymore at that time.

### Door Mirror

Order	Input	Output	Control unit condition
1	Door mirror remote control switch	—	The door mirror remote control switch signal is inputted to the automatic drive positioner control unit when the door mirror remote control switch is operated.
2	—	Motors (Door mirror motor)	The automatic drive positioner control unit actuates each motor according to the operation of the door mirror remote control switch.

#### NOTE:

The door mirrors can be operated manually when ignition switch is in either ACC or ON position. The ignition switch signal (ACC/ON) is transmitted from BCM to the driver seat control unit via CAN communication and from the driver seat control unit to the automatic drive positioner control unit via UART communication.

### MEMORY FUNCTION

A  
B  
C  
D  
E  
F  
G  
H  
I  
K  
L  
M  
N  
O  
P

ADP

# SYSTEM

< SYSTEM DESCRIPTION >

## MEMORY FUNCTION : System Description

INFOID:000000012246458

### SYSTEM DIAGRAM

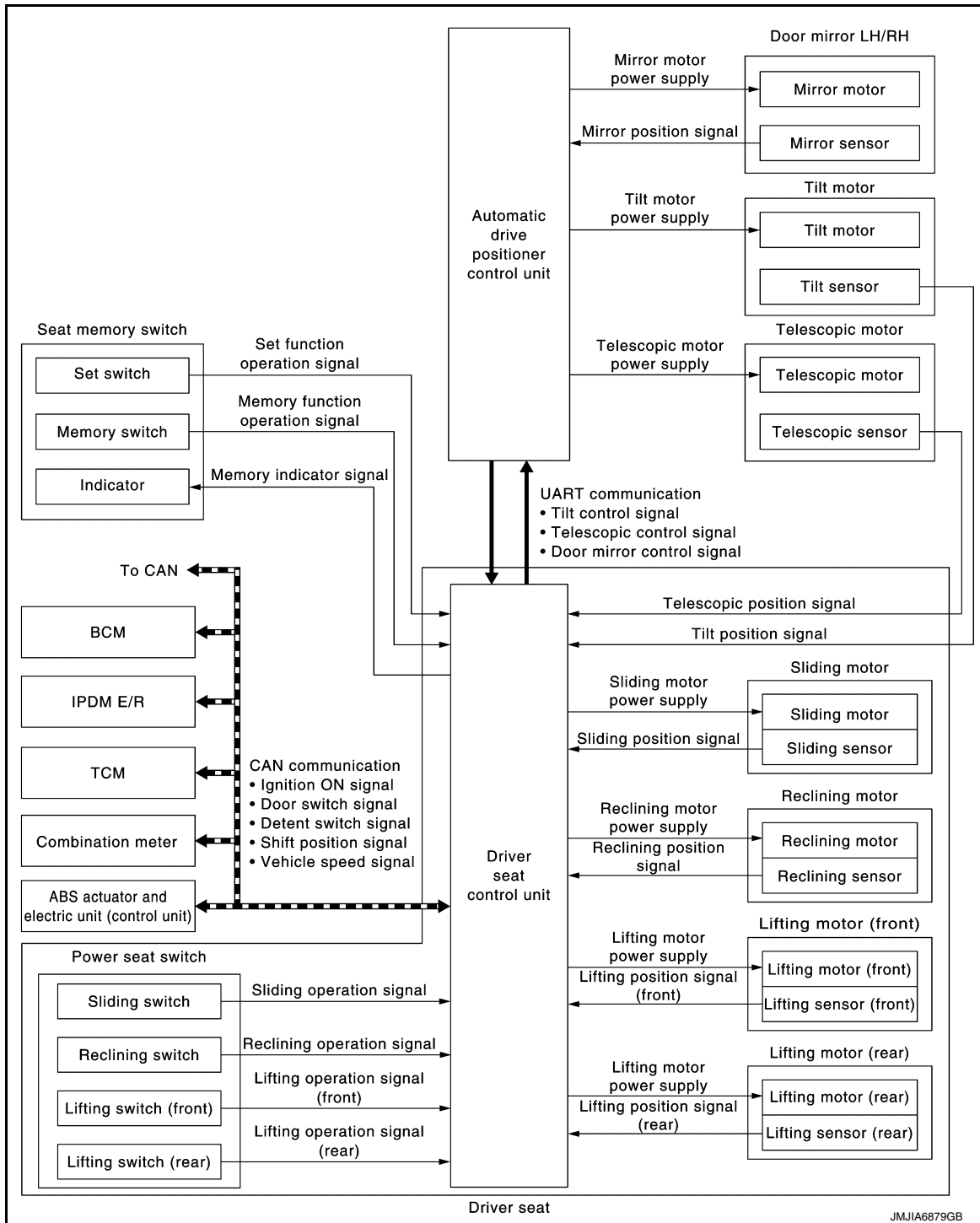

### INPUT SIGNAL AND OUTPUT SIGNAL

Several types of signals are transmitted from the following units to the driver seat control unit via CAN communication.

Component	Signal
ABS actuator and electric unit (control unit)	Vehicle speed signal
Combination meter	Vehicle speed signal
IPDM E/R	Detention switch signal



# SYSTEM

## < SYSTEM DESCRIPTION >

Component	Signal
BCM	Ignition switch signal
ECM	Shift position signal

### DESCRIPTION

The driver seat control unit can store the optimum driving positions (seat, steering column and door mirror position) for 2 people. If the front seat position is changed, one-touch (pressing desired memory switch) operation allows changing to the other driving position.

#### NOTE:

For further information on the memory storage procedure, refer to Owner's Manual.

#### Operation Procedure

1. Turn ignition switch ON/ACC.
2. Press desired memory switch.
3. Front seat LH, steering column and door mirror will move to the memorized position.

#### Operation Condition

Satisfy all of the following items. The memory function is not performed if these items are not satisfied.

Item	Request status
Switch inputs <ul style="list-style-type: none"> <li>• Power seat switch</li> <li>• ADP steering switch</li> <li>• Door mirror control switch</li> <li>• Set switch</li> <li>• Seat memory switch</li> </ul>	OFF (Not operated)
CVT selector lever	P position

#### Detail Flow

Order	Input	Output	Control unit condition
1	Memory switch	—	The memory switch signal is inputted to the automatic drive positioner control unit when memory switch 1 or 2 is operated.
2	—	Motors (seat, steering, door mirror)	Driver seat control unit operates each motor of seat when it recognizes the memory switch that is pressed and requests each motor operation to automatic drive positioner control unit via UART communication. The automatic drive positioner control unit operates each motor.
		Memory switch indicator	Driver seat control unit requests the flashing of memory indicator while either of the motors is operating. The automatic drive positioner control unit illuminates the memory indicator.
3	Sensors (seat, steering column, door mirrors)	—	Driver seat control unit judges the operating seat position with each seat sensor input. The positions of the steering column and outside mirrors are monitored with each sensor signal that is input from automatic drive positioner control unit via UART communication. Driver seat control unit stops the operation of each motor when each part reaches the recorded address.
4	—	Memory switch indicator	Driver seat control unit requests the illumination of memory indicator after all motors stop. The automatic drive positioner control unit illuminates the memory indicator for 5 seconds.

## EXIT ASSIST FUNCTION

# SYSTEM

< SYSTEM DESCRIPTION >

## EXIT ASSIST FUNCTION : System Description

INFOID:000000012246459

### SYSTEM DIAGRAM

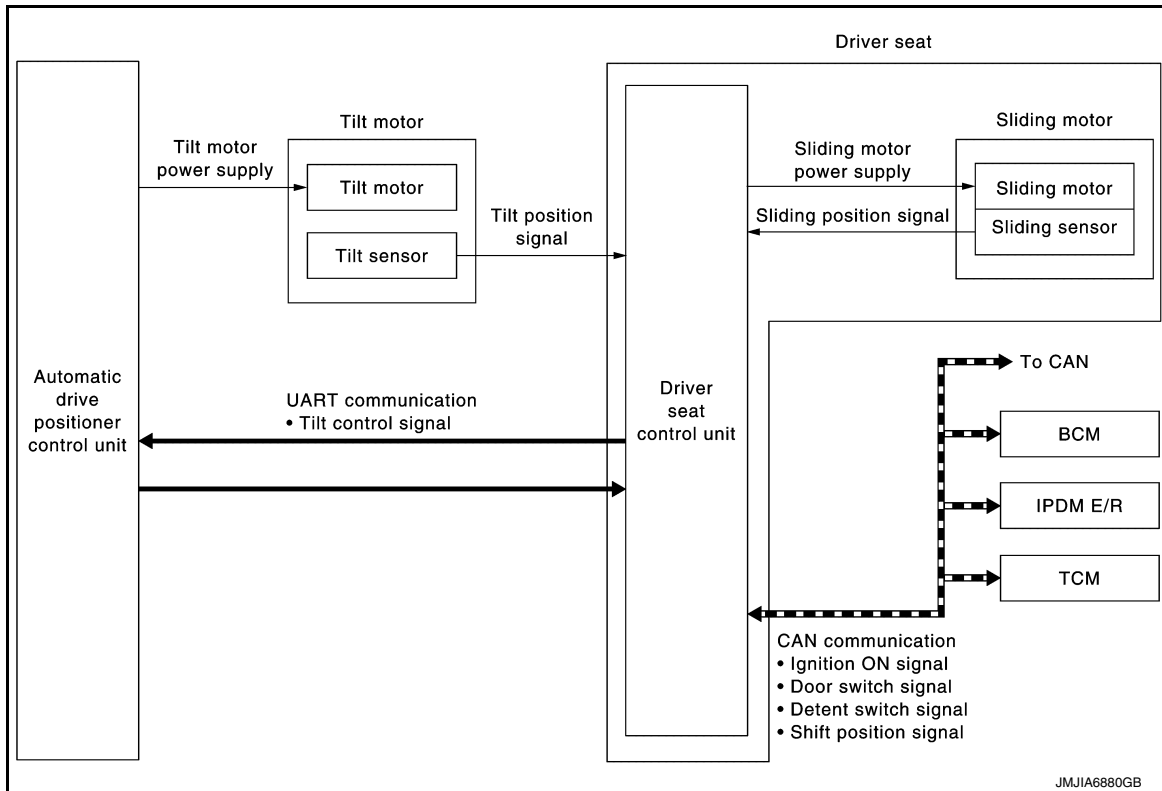

### INPUT SIGNAL AND OUTPUT SIGNAL

Several types of signals are transmitted from the following units to the driver seat control unit via CAN communication.

Component	Signal
ABS actuator and electric unit (control unit)	Vehicle speed signal
Combination meter	Vehicle speed signal
BCM	<ul style="list-style-type: none"> <li>Ignition switch signal</li> <li>Door switch signal</li> </ul>
ECM	Shift position signal
IPDM E/R	Detention switch signal

### DESCRIPTION

When exiting, if the conditions are satisfied, the seat is moved backward from normal sitting position and the steering column is moved up.

The seat slide amount at entry/exit operation can be changed.

#### NOTE:

- This function is set to ON before delivery (initial setting).
- For further information on the system setting procedure, refer to Owner's Manual.

#### Operation Procedure

- Open the front door LH with ignition switch in OFF position.
- Front seat LH and steering column will move to the exiting position.

#### Operation Condition

Satisfy all of the following items. The exit assist function is not performed if these items are not satisfied.

# SYSTEM

## < SYSTEM DESCRIPTION >

Item	Request status
Ignition switch	OFF
System setting [entry/exit assist function]	ON
Initialization	Done
Switch inputs <ul style="list-style-type: none"> <li>• Power seat switch</li> <li>• ADP steering switch</li> <li>• Door mirror remote control switch</li> <li>• Set switch</li> <li>• Seat memory switch</li> </ul>	OFF (Not operated)
CVT selector lever	P position

### Detail Flow

Order	Input	Output	Control unit condition
1	Front door switch LH	—	Driver seat control unit receives front door switch LH signal (open) from BCM via CAN communication.
2	—	Motors (seat sliding LH, tilt)	Driver seat control unit operates the seat sliding motor LH, which recognizes that the driver side door is opened with ignition switch OFF. Driver seat control unit then requests the operations of tilt motor to automatic drive positioner control unit via UART communication. The automatic drive positioner control unit operates each motor for a constant amount.

## ENTRY ASSIST FUNCTION

### ENTRY ASSIST FUNCTION : System Description

INFOID:000000012246460

### SYSTEM DIAGRAM

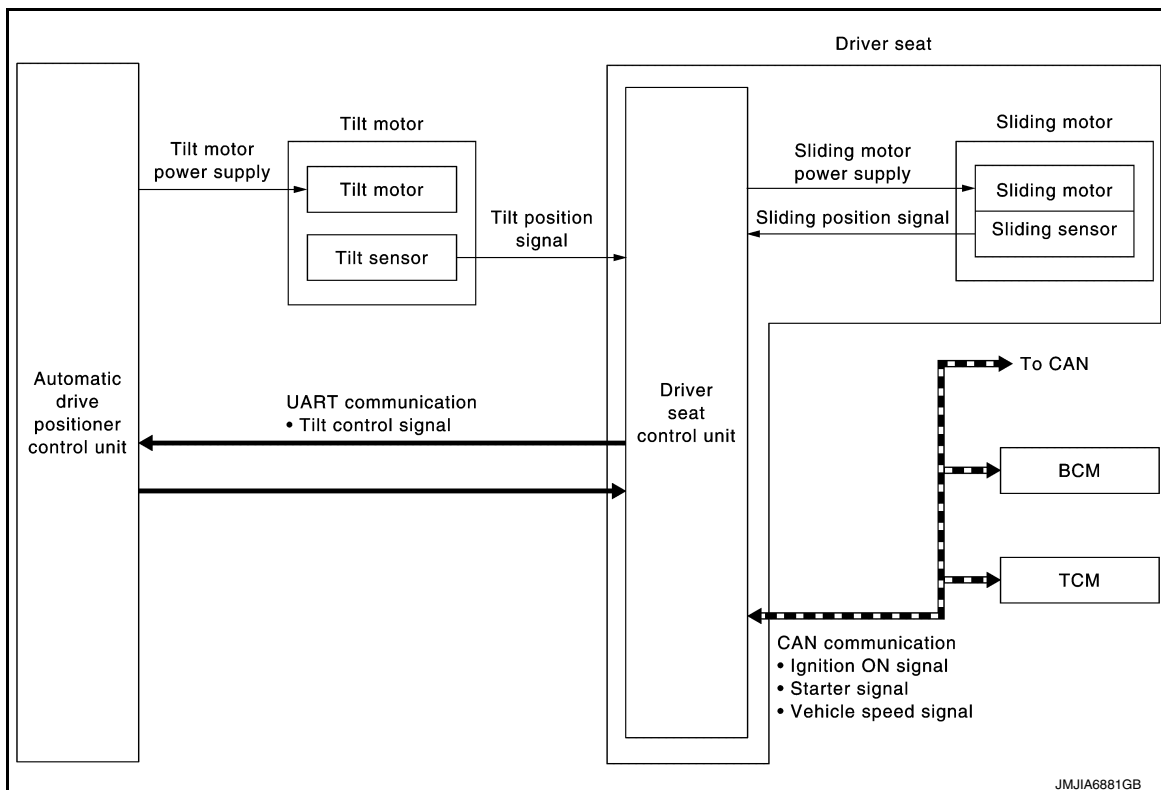

### INPUT SIGNAL AND OUTPUT SIGNAL

Several types of signals are transmitted from the following units to the driver seat control unit via CAN communication.

# SYSTEM

## < SYSTEM DESCRIPTION >

Component	Signal
ABS actuator and electric unit (control unit)	Vehicle speed signal
Combination meter	Vehicle speed signal
BCM	<ul style="list-style-type: none"> <li>• Ignition switch signal</li> <li>• Key ID signal</li> </ul>
IPDM E/R	Detention switch signal

### DESCRIPTION

The seat is in the exiting position when either of the following conditions are satisfied; the seat returns from exiting position to the previous driving position.

#### NOTE:

- This function is set to OFF before delivery (initial setting).
- For further information on the system setting procedure, refer to Owner's Manual.

#### Operation Procedure

1. Turn the ignition switch to ACC.
2. Front seat LH and steering column will return from the exiting position to entry position.

#### Operation Condition

Satisfy all of the following items. The entry assist function is not performed if these items are not satisfied.

Item	Request status
Seat, steering column	The vehicle is not moved after performing the exit assist function.
Switch inputs <ul style="list-style-type: none"> <li>• Power seat switch</li> <li>• ADP steering switch</li> <li>• Door mirror control switch</li> <li>• Set switch</li> <li>• Memory switch</li> </ul>	OFF (Not operated)
CVT selector lever	P position

#### Detail Flow

Order	Input	Output	Control unit condition
1	Door switch/Ignition switch	—	Driver seat control unit receives the signals of ignition switch signal and front door switch from BCM via CAN communication.
2	—	Motors (sliding LH, tilt)	Driver seat control unit operates the sliding motor LH when the operating conditions are satisfied and requests the operation of tilt motor to automatic drive positioner control unit via UART communication. The automatic drive positioner control unit operates the tilt motor.
	Sensors (sliding, tilt)	—	Each sensor monitors the operating positions of seat and steering column then stops the operation of motor when each part reaches the recorded address.

## LINKING KEY FOB TO THE METER DISPLAY

# SYSTEM

< SYSTEM DESCRIPTION >

## LINKING KEY FOB TO THE METER DISPLAY : System Description

INFOID:000000012246461

### SYSTEM DIAGRAM

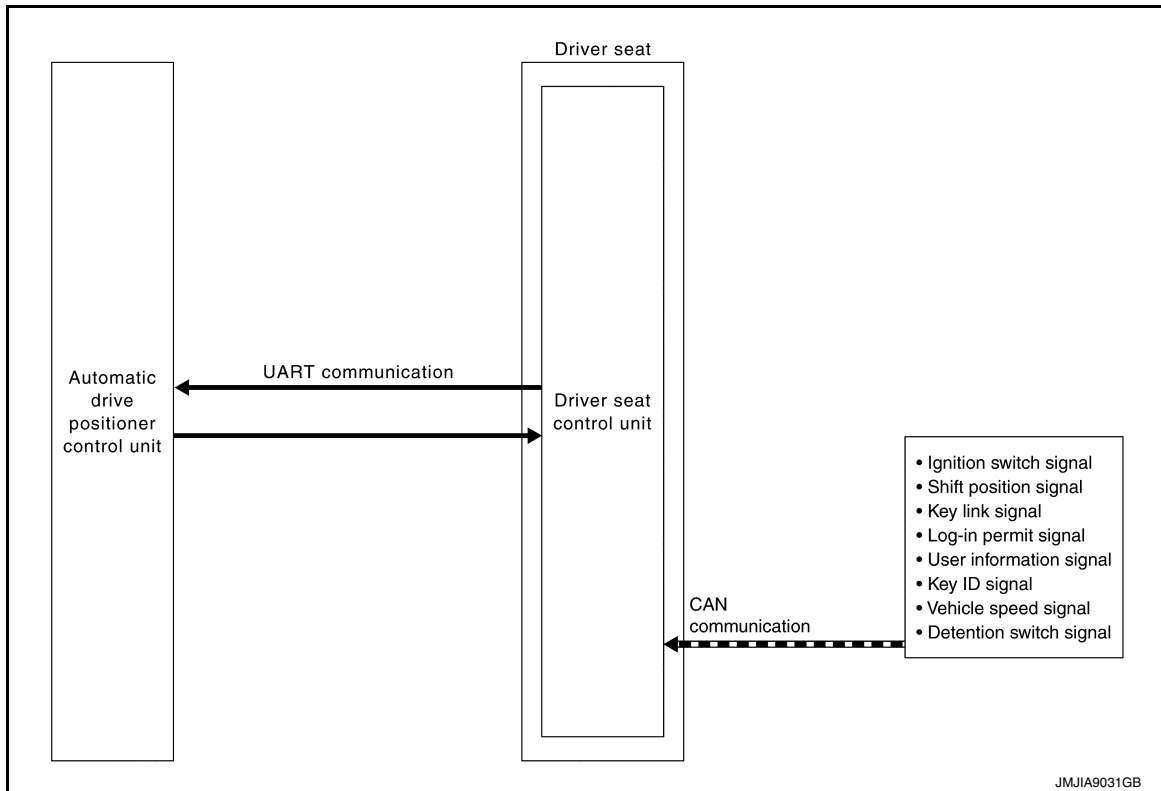

### INPUT SIGNAL AND OUTPUT SIGNAL

Several types of signals are transmitted from the following units to the driver seat control unit via CAN communication.

Component	Signal
ABS actuator and electric unit (control unit)	Vehicle speed signal
Combination meter	Vehicle speed signal
BCM	<ul style="list-style-type: none"> <li>Ignition switch signal</li> <li>Key ID signal</li> </ul>
ECM	Shift position signal
Chassis control module	<ul style="list-style-type: none"> <li>Key link signal</li> <li>Log-in permit signal</li> </ul>
Display control unit	User information signal
IPDM E/R	Detention switch signal

### DESCRIPTION

Log-in function is the function that registers the setting status of various systems and retrieves the status for each Intelligent Key as desired.

Registered information is automatically adjusted to the driving position (seat, steering column, and door mirror position) registered by unlocking the driver side door with the Intelligent Key or by operating the user selection function on the display.

When user selection is performed by display operation, the user information registered with another Intelligent Key can also be retrieved.

#### NOTE:

For the registration of the log-in function, the status is automatically registered as one of the following vehicle statuses when the ignition switch is turned to OFF. For details on registration, refer to [ADP-54, "MEMORY STORING : Description"](#).

# SYSTEM

## < SYSTEM DESCRIPTION >

Item	Request status
Ignition position	ON
Driver side door	Closed
Navigation system	Activated
CONSULT	Not connected

### Operation Procedure

1. Turn ignition switch ON.
2. Push desired user change switch on display.
3. Driver seat, steering column and door mirror will move to the memorized position.

### Operation Condition

All of the following conditions must be satisfied in order to retrieve the registration information of the log-in function.

If one of the following conditions is not satisfied, the interlocked operation of the driving position for log-in function is interrupted.

Item	Request status
Ignition position	ON
Navigation system	Activated
Initialization	Done
Switch inputs <ul style="list-style-type: none"> <li>• Power seat switch</li> <li>• Tilt &amp; telescopic switch</li> <li>• Door mirror remote control switch</li> <li>• Set switch</li> <li>• Memory switch</li> </ul>	OFF (Not operated)
CVT shift selector	P position
Log-in function memory	Registered
Vehicle speed	0 km/h (0 MPH)
CONSULT	Not connected

### Detail Flow

Order	Input	Output	Control unit condition
1	<ul style="list-style-type: none"> <li>• Door unlock signal (CAN)</li> <li>• Key ID signal (CAN)</li> </ul>	—	When the following function is performed, the driver seat control unit transmits the unlock signal from BCM via CAN communication and receives the Key ID signal. <ul style="list-style-type: none"> <li>• Unlock door: Intelligent Key</li> <li>• Unlock door: front request switch (driver side)</li> <li>• Unlock door: one touch unlock sensor</li> </ul>
2	—	—	Driver seat control unit performs the seat slide and steering tilt directly to the exit assist function. Other loads move to the exit assist function after performing log-in function.
3	—	—	Driver seat control unit performs the entry assist function.

### Fail Safe

INFOID:000000012246462

The fail-safe mode may be activated if the following symptoms are observed.

Operating in fail-safe mode	Malfunction Item	Related DTC	Diagnosis
Only manual functions operate normally.	CAN communication	U1000	<a href="#">ADP-58</a>
	CONTROL UNIT	U1010	<a href="#">ADP-59</a>
	EEPROM	B2130	<a href="#">ADP-68</a>

# SYSTEM

## < SYSTEM DESCRIPTION >

Operating in fail-safe mode	Malfunction Item	Related DTC	Diagnosis
Only manual functions, except door mirror, operate normally.	UART communication	B2128	<a href="#">ADP-66</a>
Only manual functions, except seat sliding, operate normally.	Seat sliding output	B2112	<a href="#">ADP-60</a>
Only manual functions, except seat reclining, operate normally.	Seat reclining output	B2113	<a href="#">ADP-62</a>
Only manual functions, except steering tilt, operate normally.	Steering column tilt output	B2116	<a href="#">ADP-64</a>

A

B

C

D

E

F

G

H

I

ADP

K

L

M

N

O

P

# DIAGNOSIS SYSTEM (DRIVER SEAT CONTROL UNIT)

< SYSTEM DESCRIPTION >

## DIAGNOSIS SYSTEM (DRIVER SEAT CONTROL UNIT)

### CONSULT Function (AUTO DRIVE POS.)

INFOID:000000012246463

The automatic drive positioner system can be checked and diagnosed for component operation with CONSULT.

#### APPLICATION ITEMS

Diagnostic mode	Description
ECU Identification	Displays part numbers of driver seat control unit parts.
Self Diagnostic Result	Performs self-diagnosis for the automatic drive positioner system and displays the results.
Active Test	Drives each output device.
Data Monitor	Displays input signals transmitted from various switches and sensors to driver seat control unit in real time.
Work support	Changes the setting of each function.

#### SELF DIAGNOSTIC RESULT

Refer to [ADP-32. "DTC Index"](#).

#### ACTIVE TEST

##### CAUTION:

**When driving vehicle, do not perform active test.**

Test item	Description
SEAT SLIDE	Activates/deactivates the sliding motor LH.
SEAT RECLINING	Activates/deactivates the reclining motor LH.
SEAT LIFTER FR	Activates/deactivates the lifting motor LH (front).
SEAT LIFTER RR	Activates/deactivates the lifting motor LH (rear).
TILT MOTOR	Activates/deactivates the tilt motor.
TELESCO MOTOR	Activates/deactivates the telescopic motor.
MIRROR MOTOR RH	Activates/deactivates the mirror motor LH.
MIRROR MOTOR LH	Activates/deactivates the mirror motor RH.
MEMORY SW INDCTR	Turns ON/OFF the memory indicator.

#### DATA MONITOR

Monitor Item	Unit	Main Signals	Selection From Menu	Contents
DETENT SW	"ON/OFF"	×	×	The selector lever position "OFF (P position) / ON (other than P position)" judged from the detention switch signal.
P RANG SW CAN	"ON/OFF"	×	×	ON/OFF status judged from the P range switch signal.
STARTER SW	"ON/OFF"	×	×	Ignition key switch ON (START, ON) /OFF (ACC, OFF) status judged from the ignition switch signal.
R RANGE (CAN)	"ON/OFF"	×	×	ON/OFF status judged from the R range switch signal.
VEHICLE SPEED	—	×	×	Displays the vehicle speed signal received from combination meter by numerical value [km/h].
DOOR SW-FL	"OPEN/CLOSED"	×	×	ON/OFF status judged from the door switch (front driver side) signal.
DOOR SW-FR	"OPEN/CLOSED"	×	×	ON/OFF status judged from the door switch (front passenger side) signal.
IGN ON SW	"ON/OFF"	×	×	ON/OFF status judged from the ignition switch signal.
ACC ON SW	"ON/OFF"	×	×	ON/OFF status judged from the ACC switch signal.



# DIAGNOSIS SYSTEM (DRIVER SEAT CONTROL UNIT)

## < SYSTEM DESCRIPTION >

Monitor Item	Unit	Main Signals	Selection From Menu	Contents	
KYLS DR UNLK	"ON/OFF"	×	×	ON/OFF status judged from the driver side door unlock actuator output switch signal.	A
KEYLESS ID	—	×	×	Key ID status judged from the key ID signal.	B
VHCL SPEED (ABS)	"RCV"	×	×	Vehicle speed status judged from vehicle speed signal.	C
HANDLE	"RHD/LHD"	×	×	RHD/LHD status judged from handle position signal.	C
TRANSMISSION	"AT"	×	×	CVT status judged from transmission.	D
SET SW	"ON/OFF"	×	×	ON/OFF status judged from the setting switch signal.	D
MEMORY SW1	"ON/OFF"	×	×	ON/OFF status judged from the seat memory switch 1 signal.	E
MEMORY SW2	"ON/OFF"	×	×	ON/OFF status judged from the seat memory switch 2 signal.	E
SLIDE SW-FR	"ON/OFF"	×	×	ON/OFF status judged from the sliding switch (forward) signal.	F
SLIDE SW-RR	"ON/OFF"	×	×	ON/OFF status judged from the sliding switch (backward) signal.	F
RECLN SW-FR	"ON/OFF"	×	×	ON/OFF status judged from the reclining switch (forward) signal.	G
RECLN SW-RR	"ON/OFF"	×	×	ON/OFF status judged from the reclining switch (backward) signal.	G
LIFT FR SW-UP	"ON/OFF"	×	×	ON/OFF status judged from the lifting switch front (up) signal.	H
LIFT FR SW-DN	"ON/OFF"	×	×	ON/OFF status judged from the lifting switch front (down) signal.	H
LIFT RR SW-UP	"ON/OFF"	×	×	ON/OFF status judged from the lifting switch rear (up) signal.	I
LIFT RR SW-DN	"ON/OFF"	×	×	ON/OFF status judged from the lifting switch rear (down) signal.	I
MIR CON SW-UP	"ON/OFF"	×	×	ON/OFF status judged from the mirror switch (up) signal.	ADP
MIR CON SW-DN	"ON/OFF"	×	×	ON/OFF status judged from the mirror switch (down) signal.	ADP
MIR CON SW-RH	"ON/OFF"	×	×	ON/OFF status judged from the door mirror remote control switch (passenger side) signal.	K
MIR CON SW-LH	"ON/OFF"	×	×	ON/OFF status judged from the door mirror remote control switch (driver side) signal.	K
MIR CHNG SW-R	"ON/OFF"	×	×	ON/OFF status judged from the door mirror remote control switch (switching to right) signal.	L
MIR CHNG SW-L	"ON/OFF"	×	×	ON/OFF status judged from the door mirror remote control switch (switching to left) signal.	L
TILT SW-UP	"ON/OFF"	×	×	ON/OFF status judged from the ADP steering switch (up) signal.	M
TILT SW-DOWN	"ON/OFF"	×	×	ON/OFF status judged from the ADP steering switch (down) signal.	M
TELESCO SW-FR	"ON/OFF"	×	×	ON/OFF status judged from the ADP steering switch (forward) signal.	N
TELESCO SW-RR	"ON/OFF"	×	×	ON/OFF status judged from the ADP steering switch (backward) signal.	N
SLIDE PULSE	—	—	×	Value (32768) when battery connections are standard. If it moves backward, the value increases. If it moves forward, the value decreases.	O

## DIAGNOSIS SYSTEM (DRIVER SEAT CONTROL UNIT)

### < SYSTEM DESCRIPTION >

Monitor Item	Unit	Main Signals	Selection From Menu	Contents
RECLN PULSE	—	—	×	Value (32768) when battery connections are standard. If it moves backward, the value increases. If it moves forward, the value decreases.
LIFT FR PULSE	—	—	×	Value (32768) when battery connections are standard. If it moves DOWN, the value increases. If it moves UP, the value decreases.
LIFT RR PULSE	—	—	×	Value (32768) when battery connections are standard. If it moves DOWN, the value increases. If it moves UP, the value decreases.
MIR/SEN RH U-D	“V”	—	×	Voltage input from door mirror sensor (passenger side) up/down is displayed.
MIR/SEN RH R-L	“V”	—	×	Voltage input from door mirror sensor (passenger side) left/right is displayed.
MIR/SEN LH U-D	“V”	—	×	Voltage input from door mirror sensor (driver side) up/down is displayed.
MIR/SEN LH R-L	“V”	—	×	Voltage input from door mirror sensor (driver side) left/right is displayed.
TILT PULSE	—	—	×	Value (32768) when battery connections are standard. If it moves DOWN, the value increases. If it moves UP, the value decreases.
TELESCO PULSE	—	—	×	Value (32768) when battery connections are standard. If it moves backward, the value increases. If it moves forward, the value decreases.
KEY NUMBER	—	×	×	Displays the current log-in user with the log-in function
KEY 1	—	×	×	Displays the registration or non-registration status of the log-in function
KEY 2	—	×	×	Displays the registration or non-registration status of the log-in function
KEY 3	—	×	×	Displays the registration or non-registration status of the log-in function
KEY 4	—	×	×	Displays the registration or non-registration status of the log-in function

### WORK SUPPORT

Work item	Content	Item
EXIT SEAT SLIDE SETTING	Entry/exit assist (seat) can be selected: ON (operated) – OFF (not operated)	ON
		OFF
EXIT TILT SETTING	Entry/exit assist (steering column) can be selected: ON (operated) – OFF (not operated)	ON
		OFF
SEAT SLIDE VOLUME SET	The amount of seat sliding for entry/exit assist can be selected from 3 items.	40 mm (1.6 in)
		80 mm (3.1 in)
		150 mm (6 in)

# DRIVER SEAT CONTROL UNIT

< ECU DIAGNOSIS INFORMATION >

## ECU DIAGNOSIS INFORMATION

### DRIVER SEAT CONTROL UNIT

Reference Value

INFOID:0000000012246464

#### VALUES ON THE DIAGNOSIS TOOL

CONSULT MONITOR ITEM

Monitor Item	Condition		Value/Status
ACC ON SW	Ignition switch	ACC or ON position	ON
		Other than above	OFF
DETENT SW	CVT selector lever	P position	OFF
		Other than above	ON
DOOR SW-FL	Driver door	Open	OPEN
		Close	CLOSED
DOOR SW-FR	Passenger door	Open	OPEN
		Close	CLOSED
HANDLE	Driving position		LHD
			RHD
IGN ON SW	Ignition switch	ON position	ON
		Other than above	OFF
KEYLESS ID	UNLOCK button of Intelligent Key is pressed		1, 2, 3, 4 or 5
KYLS DR UNLK	Intelligent Key or driver side door request switch	ON	ON
		OFF	OFF
LIFT FR PULSE	Seat lifter (front)	Up	The numeral value decreases *
		Down	The numeral value increases *
		Other than above	No change to numeral value *
LIFT FR SW-DN	Lifting switch front (down)	Operate	ON
		Release	OFF
LIFT FR SW-UP	Lifting switch front (up)	Operate	ON
		Release	OFF
LIFT RR PULSE	Seat lifter (rear)	Up	The numeral value decreases *
		Down	The numeral value increases *
		Other than above	No change to numeral value *
LIFT RR SW-DN	Lifting switch rear (down)	Operate	ON
		Release	OFF
LIFT RR SW-UP	Lifting switch rear (up)	Operate	ON
		Release	OFF
MEMORY SW1	Memory switch 1	Push	ON
		Release	OFF
MEMORY SW2	Memory switch 2	Push	ON
		Release	OFF
MIR CHNG SW-L	Select switch	Left	ON
		Other than above	OFF
MIR CHNG SW-R	Select switch	Right	ON
		Other than above	OFF

A  
B  
C  
D  
E  
F  
G  
H  
I  
K  
L  
M  
N  
O  
P

ADP

# DRIVER SEAT CONTROL UNIT

## < ECU DIAGNOSIS INFORMATION >

Monitor Item	Condition		Value/Status
MIR CON SW-DN	Mirror switch	Down	ON
		Other than above	OFF
MIR CON SW-LH	Mirror switch	Left	ON
		Other than above	OFF
MIR CON SW-RH	Mirror switch	Right	ON
		Other than above	OFF
MIR CON SW-UP	Mirror switch	Up	ON
		Other than above	OFF
MIR/SEN LH R-L	Door mirror (driver side)		Change between 0.6 (close to left edge) and 3.4 (close to right edge)
MIR/SEN LH U-D	Door mirror (driver side)		Change between 3.4 (close to peak) and 0.6 (close to valley)
MIR/SEN RH R-L	Door mirror (passenger side)		Change between 3.4 (close to left edge) and 0.6 (close to right edge)
MIR/SEN RH U-D	Door mirror (passenger side)		Change between 3.4 (close to peak) and 0.6 (close to valley)
P RANG SW CAN	CVT selector lever	P position	ON
		Other than above	OFF
R RANGE (CAN)	CVT selector lever	R position	ON
		Other than above	OFF
RECLN PULSE	Seat reclining	Forward	The numeral value decreases*
		Backward	The numeral value increases *
		Other than above	No change to numeral value *
RECLN SW-FR	Reclining switch (forward)	Operate	ON
		Release	OFF
RECLN SW-RR	Reclining switch (backward)	Operate	ON
		Release	OFF
SET SW	Set switch	Push	ON
		Release	OFF
SLIDE PULSE	Seat sliding	Forward	The numeral value decreases *
		Backward	The numeral value increases*
		Other than above	No change to numeral value*
SLIDE SW-FR	Sliding switch (forward)	Operate	ON
		Release	OFF
SLIDE SW-RR	Sliding switch (backward)	Operate	ON
		Release	OFF
STARTER SW	Ignition position	Cranking	ON
		Other than above	OFF
TELESCO PULSE	Telescopic position	Forward	The numeral value decreases *
		Backward	The numeral value increases *
		Other than above	No change to numeral value*
TELESCO SW-FR	Telescopic switch	Forward	ON
		Other than above	OFF
TELESCO SW-RR	Telescopic switch	Backward	ON
		Other than above	OFF

# DRIVER SEAT CONTROL UNIT

## < ECU DIAGNOSIS INFORMATION >

Monitor Item	Condition		Value/Status
TILT PULSE	Tilt position	Upward	The numeral value decreases *
		Downward	The numeral value increases *
		Other than above	No change to numeral value *
TILT SW-DOWN	Tilt switch	Downward	ON
		Other than above	OFF
TILT SW-UP	Tilt switch	Upward	ON
		Other than above	OFF
TRANSMISSION	Transmission type		A/T
VEHICLE SPEED	The condition of vehicle speed is displayed		km/h
VHCL SPEED (ABS)	CAN signal from ABS	Received	ON
		Not received	OFF

\*: The value at the position attained when the battery is connected is regarded as 32768.

## TERMINAL LAYOUT

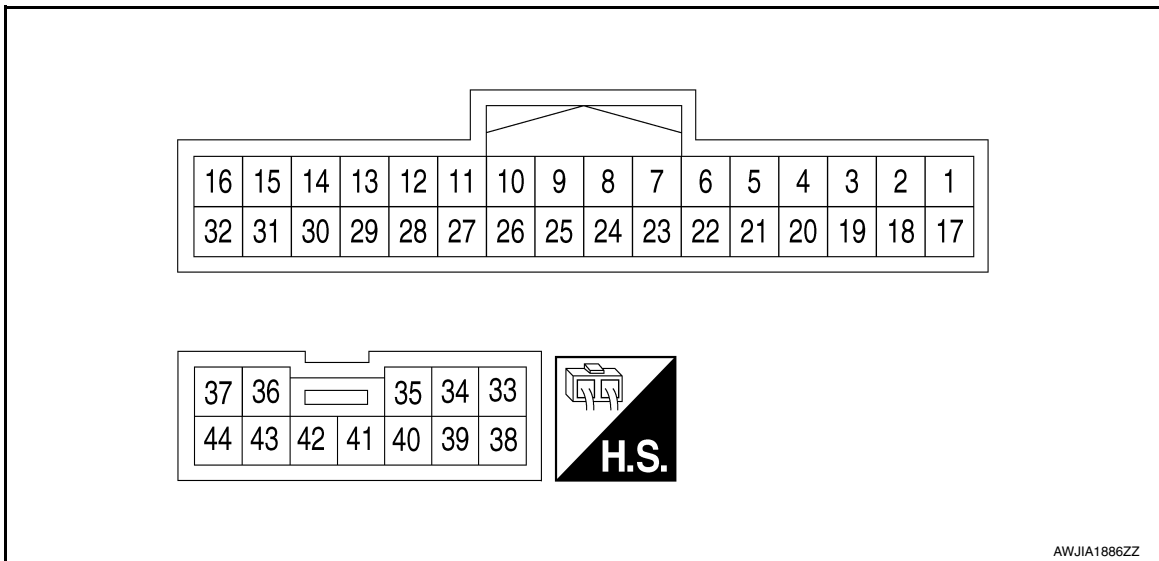

## PHYSICAL VALUES

Terminal No. (Wire color)		Description		Condition	Voltage (V) (Approx.)
+	-	Signal name	Input/ Output		
5 (SB)	Ground	Sensor power supply	Output	—	Battery voltage
6 (G)	Ground	Lifting switch (rear) down signal	Input	Lifting switch (rear)	Operate (down) 0 Release Battery voltage
				Lifting switch (front)	Operate (down) 0 Release Battery voltage
8 (W)	Ground	Reclining switch backward signal	Input	Reclining switch	Operate (backward) 0 Release Battery voltage

# DRIVER SEAT CONTROL UNIT

## < ECU DIAGNOSIS INFORMATION >

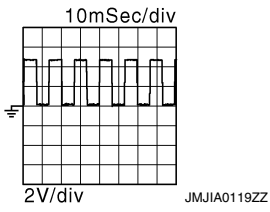
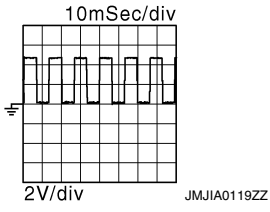
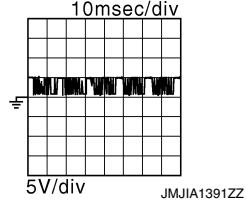
Terminal No. (Wire color)		Description		Condition		Voltage (V) (Approx.)
+	-	Signal name	Input/ Output			
9 (V)	Ground	Sliding switch backward signal	Input	Sliding switch	Operate (backward)	0
					Release	Battery voltage
10 (G)	Ground	Memory indicator 2 signal	Output	Memory indicator 2	Illuminate	1
					Other than above	Battery voltage
11 (GR)	Ground	Memory switch 2 signal	Input	Memory switch 2	Press	0
					Other than above	5
12 (V)	Ground	Telescopic sensor signal	Input	Telescopic	Operate	 <small>10mSec/div</small> <small>2V/div</small> <small>JMJIA0119ZZ</small>
					Other than above	0 or 5
13 (P)	Ground	Reclining sensor signal	Input	Seat reclining	Operate	 <small>10mSec/div</small> <small>2V/div</small> <small>JMJIA0119ZZ</small>
					Stop	0 or 5
15 (BR)	Ground	UART communication (TX/RX)	Input	Ignition switch ON	 <small>10msec/div</small> <small>5V/div</small> <small>JMJIA1391ZZ</small>	
16 (L)	—	CAN high	—	—	—	
21 (Y)	Ground	Set switch signal	Input	Set switch	Press	0
					Other than above	5
22 (O)	Ground	Lifting switch (rear) up sig- nal	Input	Seat lifting switch (rear)	Operate (up)	0
					Release	Battery voltage
23 (G)	Ground	Lifting switch (front) up sig- nal	Input	Seat lifting switch (front)	Operate (up)	0
					Release	Battery voltage
24 (W)	Ground	Reclining switch forward signal	Input	Reclining switch	Operate (forward)	0
					Release	Battery voltage
25 (L)	Ground	Sliding switch forward sig- nal	Input	Sliding switch	Operate (forward)	0
					Release	Battery voltage

# DRIVER SEAT CONTROL UNIT

## < ECU DIAGNOSIS INFORMATION >

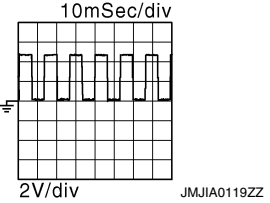
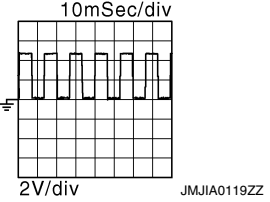
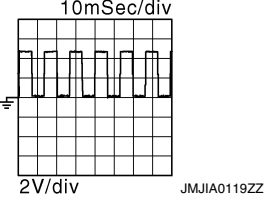
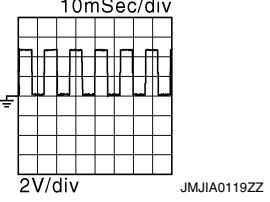
Terminal No. (Wire color)		Description		Condition		Voltage (V) (Approx.)
+	-	Signal name	Input/ Output			
26 (W)	Ground	Memory indicator 1 signal	Output	Memory indicator 1	Illuminate	1
					Other than above	Battery voltage
27 (O)	Ground	Memory switch 1 signal	Input	Memory switch 1	Press	0
					Other than above	5
28 (SB)	Ground	Tilt sensor signal	Input	Tilt	Operate	
					Other than above	0 or 5
29 (GR)	Ground	Lifting sensor (rear) signal	Input	Seat lifting (rear)	Operate	
					Stop	0 or 5
30 (W)	Ground	Lifting sensor (front) signal	Input	Seat lifting (front)	Operate	
					Stop	0 or 5
31 (LG)	Ground	Sliding sensor signal	Input	Seat sliding	Operate	
					Stop	0 or 5
32 (P)	—	CAN low	—	—	—	—
34 (O)	Ground	Lifting motor LH (front) up signal	Output	Seat lifting (front)	Operate (up)	Battery voltage
					Stop	0
35 (Y)	Ground	Reclining motor LH forward signal	Output	Seat reclining	Operate (forward)	Battery voltage
					Release	0
36 (V)	Ground	Sliding motor LH backward signal	Output	Seat sliding	Operate (backward)	Battery voltage
					Stop	0

A  
B  
C  
D  
E  
F  
G  
H  
I  
K  
L  
M  
N  
O  
P

ADP

# DRIVER SEAT CONTROL UNIT

## < ECU DIAGNOSIS INFORMATION >

Terminal No. (Wire color)		Description		Condition		Voltage (V) (Approx.)
+	-	Signal name	Input/ Output			
37 (R)	Ground	Power source	Input	—		Battery voltage
39 (B)	Ground	Ground (power)	—	—		0
40 (G)	Ground	Lifting motor LH (rear) down signal	Output	Seat lifting (rear)	Operate (down)	Battery voltage
					Stop	0
41 (L)	Ground	Lifting motor LH (rear) up signal	Output	Seat lifting (rear)	Operate (up)	Battery voltage
					Stop	0
42 (GR)	Ground	Lifting motor LH (front) down signal	Output	Seat lifting (front)	Operate (down)	Battery voltage
					Stop	0
43 (W)	Ground	Reclining motor LH back- ward signal	Output	Seat reclining	Operate (backward)	Battery voltage
					Stop	0
44 (P)	Ground	Sliding motor LH forward signal	Output	Seat sliding	Operate (forward)	Battery voltage
					Release	0

### Fail Safe

INFOID:0000000012246466

The fail-safe mode may be activated if the following symptoms are observed.

Operating in fail-safe mode	Malfunction Item	Related DTC	Diagnosis
Only manual functions operate normally.	CAN communication	U1000	<a href="#">ADP-58</a>
	CONTROL UNIT	U1010	<a href="#">ADP-59</a>
	EEPROM	B2130	<a href="#">ADP-68</a>
Only manual functions, except door mirror, operate normally.	UART communication	B2128	<a href="#">ADP-66</a>
Only manual functions, except seat sliding, operate normally.	Seat sliding output	B2112	<a href="#">ADP-60</a>
Only manual functions, except seat reclining, operate normally.	Seat reclining output	B2113	<a href="#">ADP-62</a>
Only manual functions, except steering tilt, operate normally.	Steering column tilt output	B2116	<a href="#">ADP-64</a>

### DTC Index

INFOID:0000000012246466

CONSULT display	Timing*1		Item	Reference page
	Current mal- function	Previous mal- function		
CAN COMM CIRCUIT [U1000]	0	1-39	CAN communication	<a href="#">ADP-58</a>
CONTROL UNIT [U1010]	0	1-39	Control unit	<a href="#">ADP-59</a>
SEAT SLIDE [B2112]	0	1-39	Seat slide motor output	<a href="#">ADP-60</a>
SEAT RECLINING [B2113]	0	1-39	Seat reclining motor output	<a href="#">ADP-62</a>



# DRIVER SEAT CONTROL UNIT

## < ECU DIAGNOSIS INFORMATION >

CONSULT display	Timing*1		Item	Reference page
	Current mal-function	Previous mal-function		
STEERING TILT [B2116]	0	1-39	Tilt motor output	<a href="#">ADP-64</a>
UART COMM [B2128]	0	1-39	UART communication	<a href="#">ADP-66</a>
EEPROM [B2130]	0	1-39	EEPROM	<a href="#">ADP-68</a>

\*1:

- 0: Current malfunction is present.
- 1-39: Displayed if any previous malfunction is present when current condition is normal. The numeral value increases by one at each IGN ON to OFF cycle from 1 to 39. The counter remains at 39 even if the number of cycles exceeds it. However, the counter is reset to 1 if any malfunction is detected again, the normal operation is resumed and the ignition switch is turned from OFF to ON.

A  
B  
C  
D  
E  
F  
G  
H  
I  
K  
L  
M  
N  
O  
P

ADP

# AUTOMATIC DRIVE POSITIONER CONTROL UNIT

< ECU DIAGNOSIS INFORMATION >

## AUTOMATIC DRIVE POSITIONER CONTROL UNIT

Reference Value

INFOID:000000012246467

### TERMINAL LAYOUT

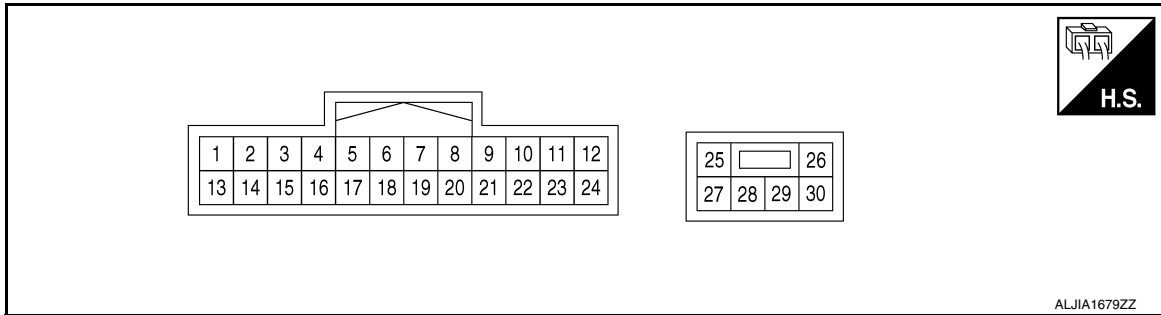

### PHYSICAL VALUES

Terminal No. (Wire color)		Description		Condition		Voltage (V) (Approx.)
+	-	Signal name	Input/ Output			
1 (G)	Ground	Tilt switch up signal	Input	Tilt switch	Operate (up)	0
					Other than above	5
2 (LG)	Ground	Select switch RH signal	Input	Select switch position	RH	0
					Neutral or LH	5
3 (L)	Ground	Mirror switch up signal	Input	Mirror switch	Operate (up)	0
					Other than above	5
4 (V)	Ground	Mirror switch left signal	Input	Mirror switch	Operate (left)	0
					Other than above	5
5 (W)	Ground	Door mirror sensor (passenger side) up/down signal	Input	Door mirror RH position		Change between 3.4 (close to peak) and 0.6 (close to valley)
6 (R)	Ground	Door mirror sensor (driver side) up/down signal	Input	Door mirror LH position		Change between 3.4 (close to peak) and 0.6 (close to valley)
7 (P)	Ground	Telescopic switch forward signal	Input	Telescopic switch	Operate (forward)	0
					Other than above	5
8 (SB)	Ground	UART communication (TX/RX)	Output	Ignition switch ON		 5V/div 10msec/div JMJA1391ZZ

# AUTOMATIC DRIVE POSITIONER CONTROL UNIT

## < ECU DIAGNOSIS INFORMATION >

Terminal No. (Wire color)		Description		Condition		Voltage (V) (Approx.)
+	-	Signal name	Input/ Output			
10 (W)	Ground	Door mirror motor (passenger side) up signal	Output	Door mirror RH	Operate (up)	Battery voltage
					Other than above	0
11 (G)	Ground	Door mirror motor (passenger side) left signal	Output	Door mirror RH	Operate (left)	Battery voltage
					Other than above	0
12 (BG)	Ground	Door mirror motor (driver side) down signal	Output	Door mirror LH	Operate (down)	Battery voltage
					Other than above	0
		Door mirror motor (driver side) right signal			Operate (right)	Battery voltage
					Other than above	0
13 (R)	Ground	Tilt switch down signal	Input	Tilt switch	Operate (down)	0
					Other than above	5
14 (BR)	Ground	Select switch LH signal	Input	Select switch position	LH	0
					Neutral or RH	5
15 (Y)	Ground	Mirror switch down signal	Input	Mirror switch	Operate (down)	0
					Other than above	5
16 (SB)	Ground	Mirror switch right signal	Input	Mirror switch	Operate (right)	0
					Other than above	5
17 (P)	Ground	Door mirror sensor (passenger side) left/right signal	Input	Door mirror RH position		Change between 3.4 (close to left edge) and 0.6 (close to right edge)
18 (BG)	Ground	Door mirror sensor (driver side) left/right signal	Input	Door mirror LH position		Change between 0.6 (close to left edge) and 3.4 (close to right edge)
19 (W)	Ground	Telescopic switch backward signal	Input	Telescopic switch	Operate (backward)	0
					Other than above	5
20 (Y)	Ground	Ground	—	—		0
21 (G)	Ground	Door mirror motor sensor power supply	Input	—		5

A  
B  
C  
D  
E  
F  
G  
H  
I  
ADP  
K  
L  
M  
N  
O  
P

# AUTOMATIC DRIVE POSITIONER CONTROL UNIT

## < ECU DIAGNOSIS INFORMATION >

Terminal No. (Wire color)		Description		Condition	Voltage (V) (Approx.)	
+	-	Signal name	Input/ Output			
22 (BG)	Ground	Door mirror motor (passenger side) down signal	Output	Door mirror (RH)	Operate (down)	Battery voltage
					Other than above	0
		Door mirror motor (passenger side) right signal			Operate (right)	Battery voltage
					Other than above	0
23 (R)	Ground	Door mirror motor (driver side) up signal	Output	Door mirror (LH)	Operate (up)	Battery voltage
					Other than above	0
24 (P)	Ground	Door mirror motor (driver side) left signal	Output	Door mirror (LH)	Operate (left)	Battery voltage
					Other than above	0
25 (L)	Ground	Power source	Input	—	Battery voltage	
26 (V)	Ground	Telescopic motor backward signal	Output	Steering telescopic	Operate (backward)	Battery voltage
					Other than above	0
27 (LG)	Ground	Tilt and telescopic motor power source		—	Battery voltage	
28 (SB)	Ground	Tilt motor down signal	Output	Steering tilt	Operate (down)	Battery voltage
					Other than above	0
29 (BR)	Ground	Tilt motor up signal	Output	Steering tilt	Operate (up)	Battery voltage
					Other than above	0
		Telescopic motor forward signal		Steering telescopic	Operate (forward)	Battery voltage
					Other than above	0
30 (B)	Ground	Ground	—	—	0	

# BCM (BODY CONTROL MODULE)

< ECU DIAGNOSIS INFORMATION >

## BCM (BODY CONTROL MODULE)

### List of ECU Reference

INFOID:000000012246468

ECU	Reference
BCM	<a href="#">BCS-31. "Reference Value"</a>
	<a href="#">BCS-51. "Fail Safe"</a>
	<a href="#">BCS-52. "DTC Inspection Priority Chart"</a>
	<a href="#">BCS-53. "DTC Index"</a>

A

B

C

D

E

F

G

H

I

ADP

K

L

M

N

O

P

# AUTOMATIC DRIVE POSITIONER SYSTEM

< WIRING DIAGRAM >

## WIRING DIAGRAM

### AUTOMATIC DRIVE POSITIONER SYSTEM

Wiring Diagram

INFOID:000000012246469

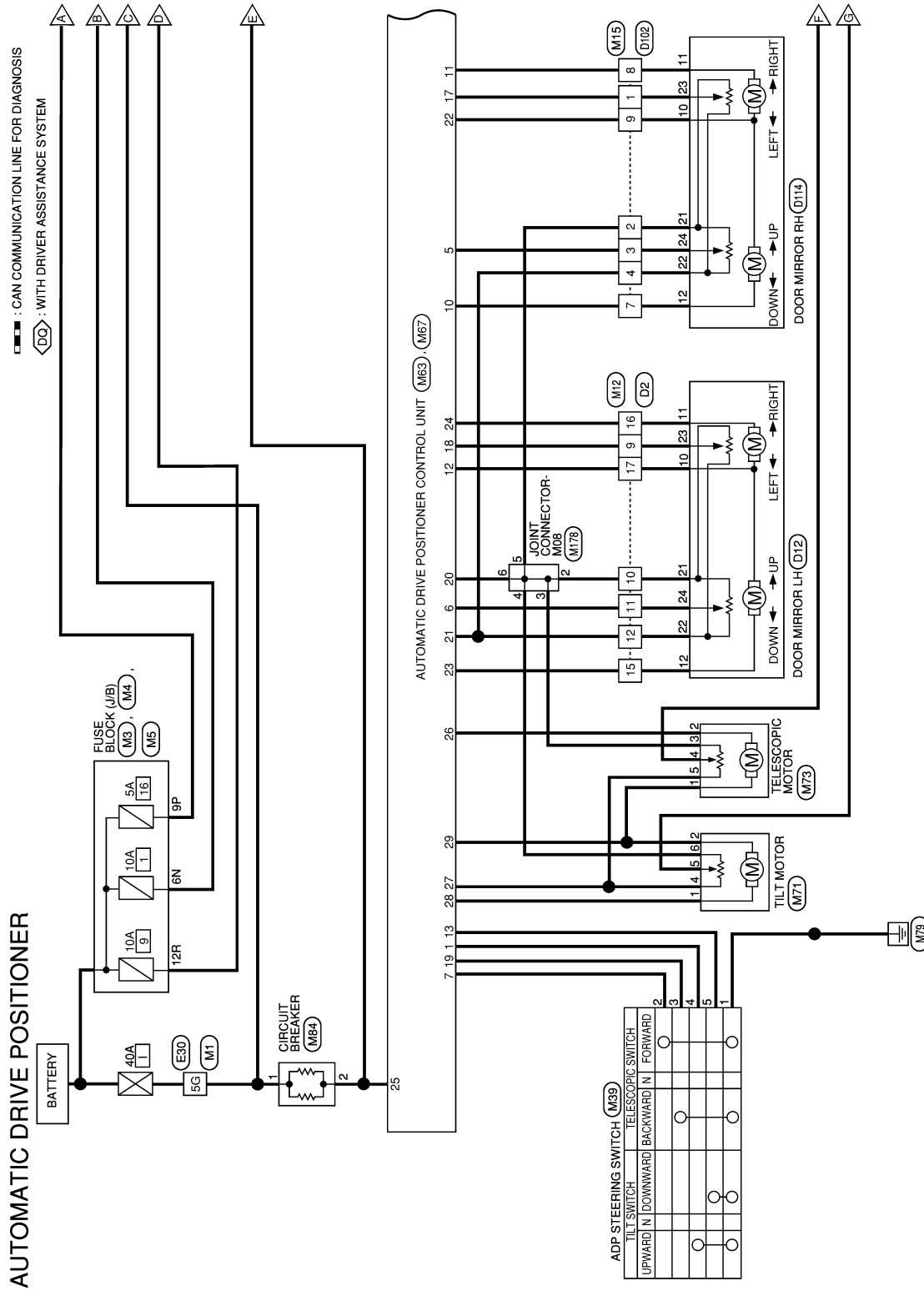

AAJWA0340GB

# AUTOMATIC DRIVE POSITIONER SYSTEM

< WIRING DIAGRAM >

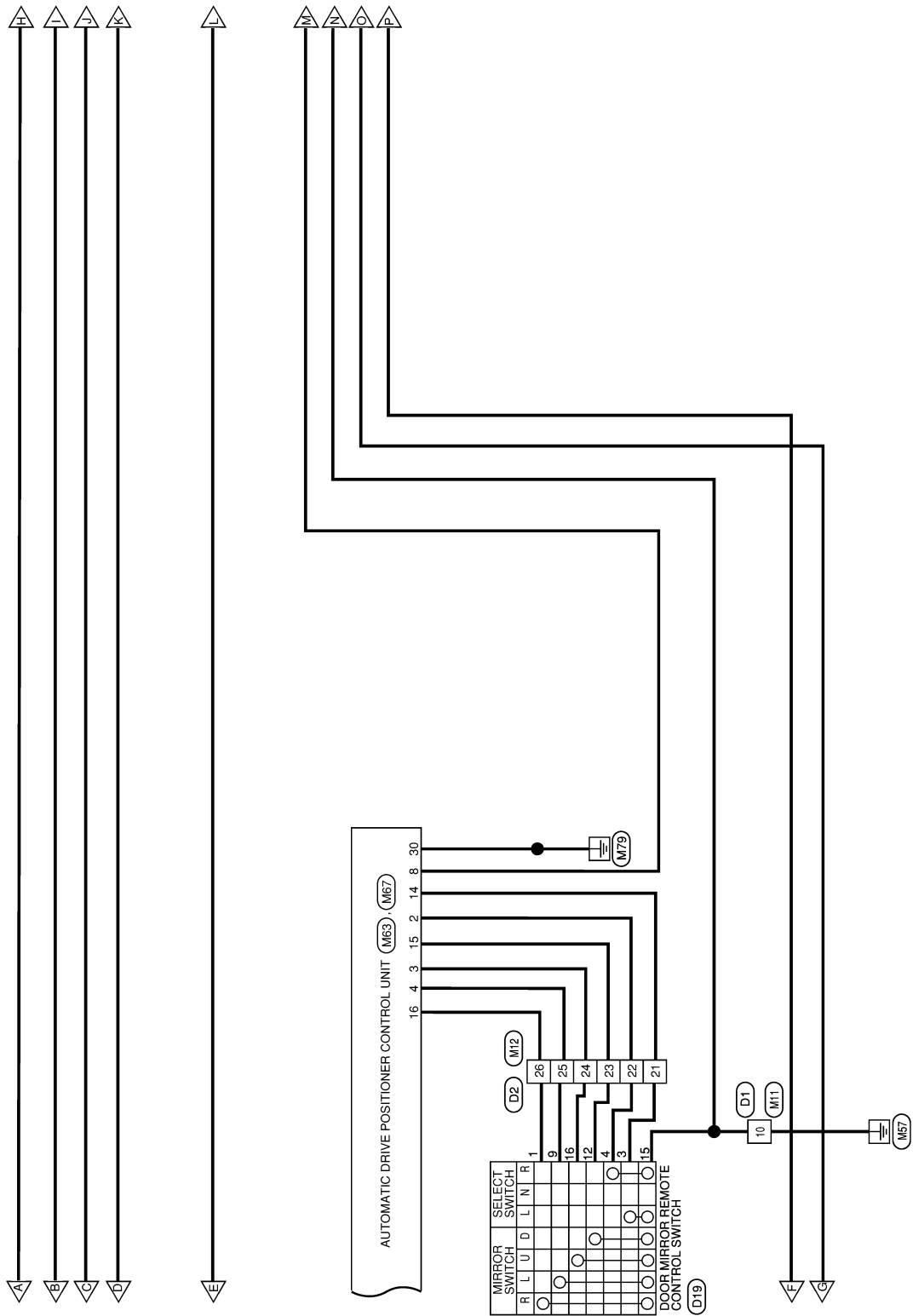

A  
B  
C  
D  
E  
F  
G  
H  
I  
ADP  
K  
L  
M  
N  
O  
P

AAJWA0341GB

# AUTOMATIC DRIVE POSITIONER SYSTEM

< WIRING DIAGRAM >

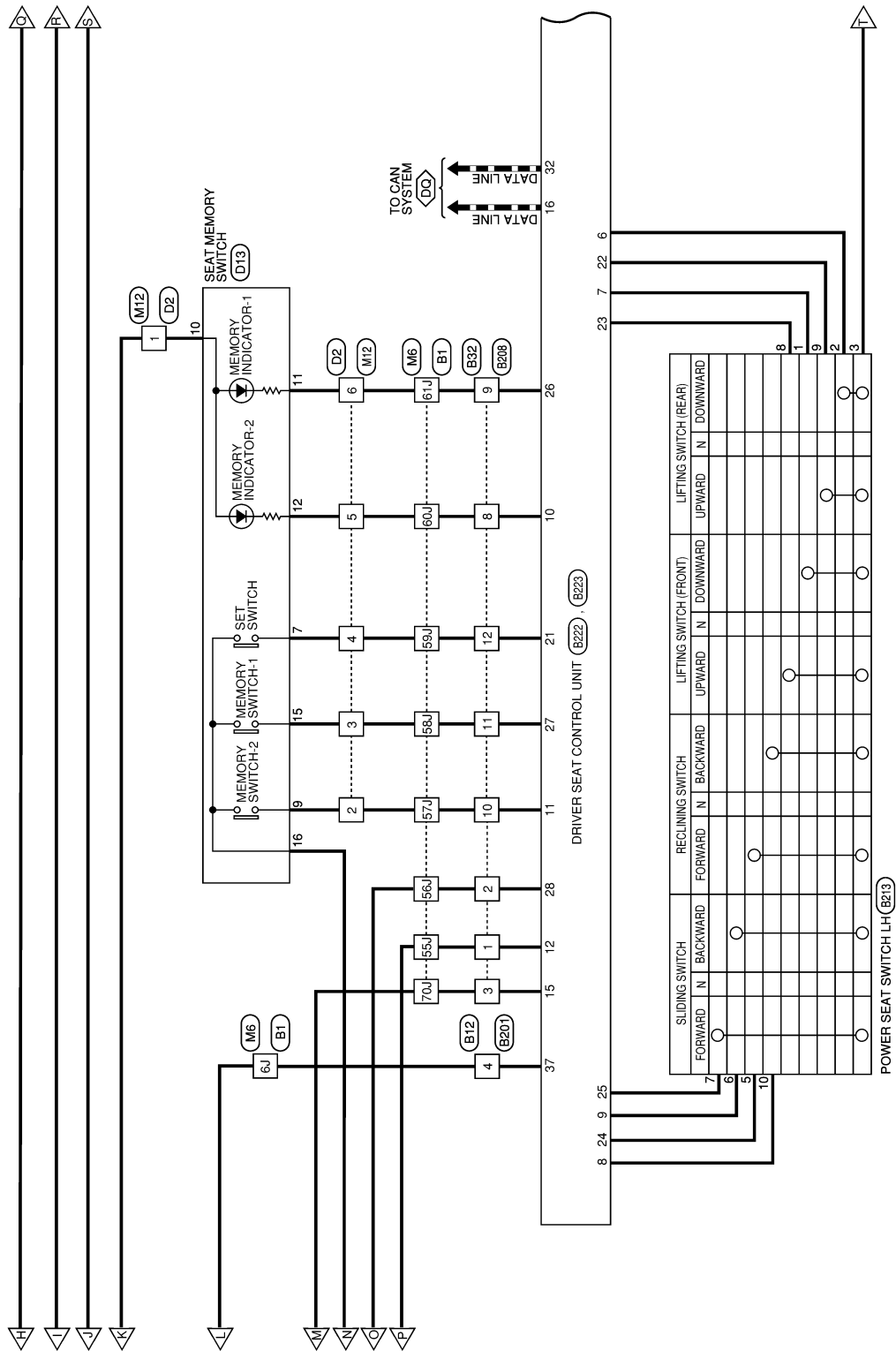

AAJWA0342GB



# AUTOMATIC DRIVE POSITIONER SYSTEM

< WIRING DIAGRAM >

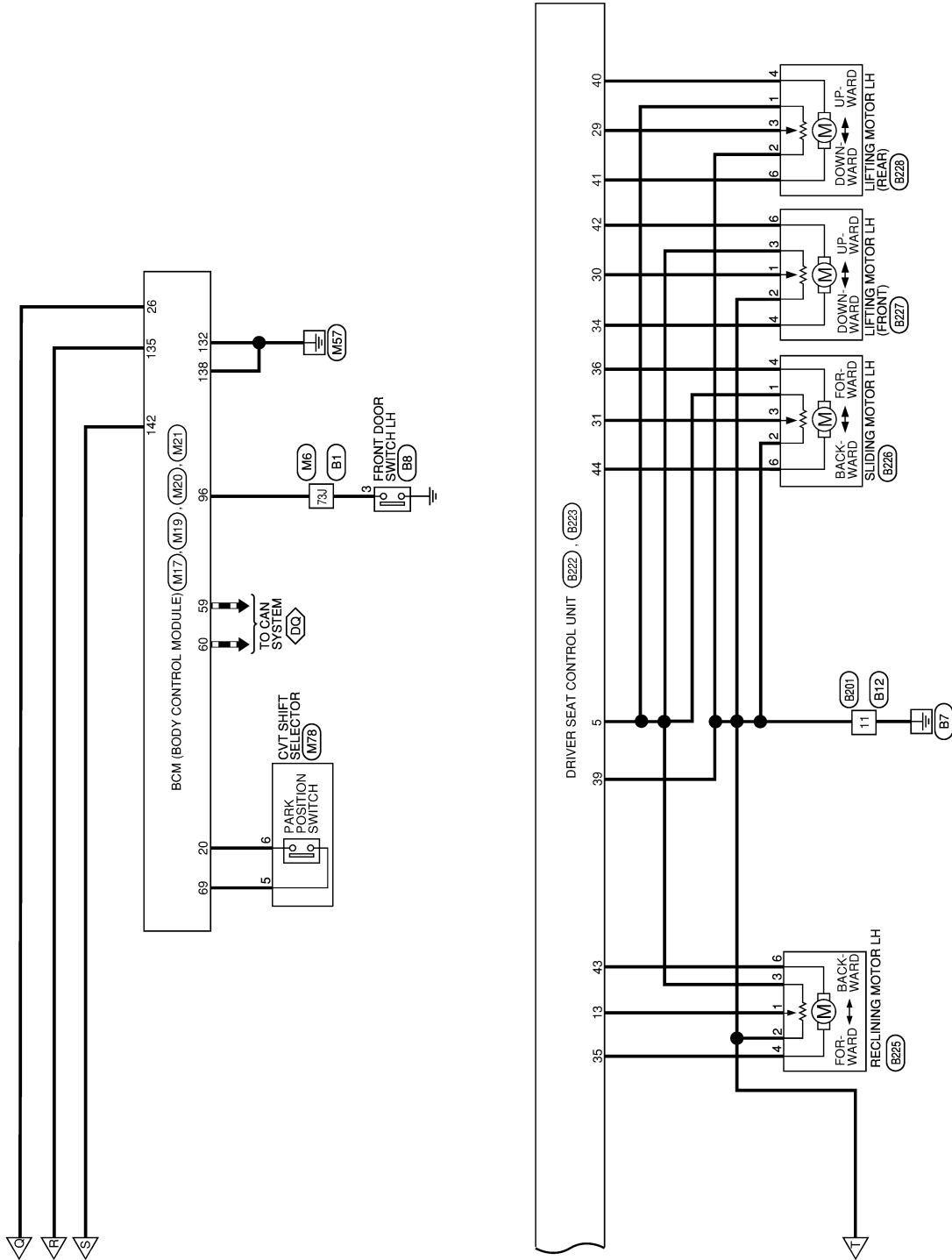

AAJWA0343GB

A  
B  
C  
D  
E  
F  
G  
H  
I  
ADP  
K  
L  
M  
N  
O  
P

# AUTOMATIC DRIVE POSITIONER SYSTEM

< WIRING DIAGRAM >

## AUTOMATIC DRIVE POSITIONER CONNECTORS

Connector No.	M1
Connector Name	WIRE TO WIRE
Connector Type	TH80FW-CS16-TM4
Connector Color	WHITE

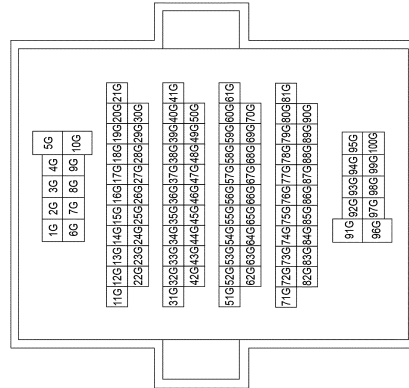

Terminal No.	5G	Color of Wire	W	Signal Name	-
--------------	----	---------------	---	-------------	---

Connector No.	M3
Connector Name	FUSE BLOCK (J/B)
Connector Type	CS06FW-M2
Connector Color	WHITE

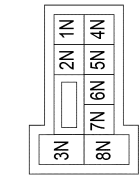

Terminal No.	6N	Color of Wire	LG	Signal Name	-
--------------	----	---------------	----	-------------	---

Connector No.	M4
Connector Name	FUSE BLOCK (J/B)
Connector Type	NS16FBR-CS
Connector Color	BROWN

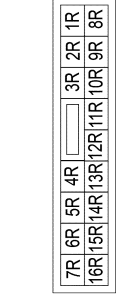

Terminal No.	12R	Color of Wire	W	Signal Name	-
--------------	-----	---------------	---	-------------	---

Connector No.	M5
Connector Name	FUSE BLOCK (J/B)
Connector Type	NS16FW-CS
Connector Color	WHITE

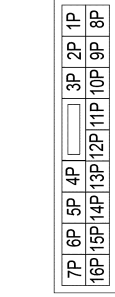

Terminal No.	9P	Color of Wire	Y	Signal Name	-
--------------	----	---------------	---	-------------	---

Connector No.	M6
Connector Name	WIRE TO WIRE
Connector Type	TH80FDGY-CS16-TM4
Connector Color	GRAY

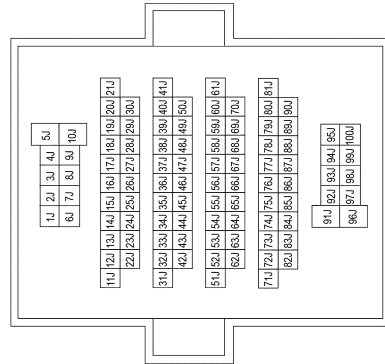

Terminal No.	Color of Wire	Signal Name
6J	V	- (WITHOUT AUTOMATIC DRIVE POSITIONER)
6J	L	- (WITH AUTOMATIC DRIVE POSITIONER)
65J	SB	-
66J	L	-
67J	LG	-
68J	V	-
69J	SB	-
60J	BR	-
61J	Y	-
70J	SB	-
73J	P	-

# AUTOMATIC DRIVE POSITIONER SYSTEM

< WIRING DIAGRAM >

Connector No.	M19
Connector Name	BCM (BODY CONTROL MODULE)
Connector Type	TH24FGY-NH
Connector Color	GRAY



92	91	90	89	88	87	86	85	84	83	82	81
104	103	102	101	100	99	98	97	96	95	94	93

Terminal No.	Color of Wire	Signal Name
96	P	DR DOOR SW

Connector No.	M20
Connector Name	BCM (BODY CONTROL MODULE)
Connector Type	TH40FB-NH
Connector Color	BLACK



60	59	58	57	56	55	54	53	52	51	50	49	48	47	46	45	44	43	42	41
80	79	78	77	76	75	74	73	72	71	70	69	68	67	66	65	64	63	62	61

Terminal No.	Color of Wire	Signal Name
59	P	CAN-L
60	L	CAN-H
69	L	AT DEVICE OUT

Connector No.	M21
Connector Name	BCM (BODY CONTROL MODULE)
Connector Type	TH40FG-NH
Connector Color	GREEN



20	19	18	17	16	15	14	13	12	11	10	9	8	7	6	5	4	3	2	1
40	39	38	37	36	35	34	33	32	31	30	29	28	27	26	25	24	23	22	21

Terminal No.	Color of Wire	Signal Name
20	W	SHIFT P
26	Y	SHORTING INPUT

Connector No.	M15
Connector Name	WIRE TO WIRE
Connector Type	TH24MW-NH
Connector Color	WHITE



1	2	3	4	5	6	7	8	9	10	11	12
13	14	15	16	17	18	19	20	21	22	23	24

Terminal No.	Color of Wire	Signal Name
1	P	-
2	Y	-
3	W	-
4	G	-
7	W	-
8	G	-
9	BG	-

Connector No.	M17
Connector Name	BCM (BODY CONTROL MODULE)
Connector Type	FEA09FW-FHA6-SA
Connector Color	WHITE



129	130	131	132	133	134	135	136	137
138	139	140	141	142	143			

Terminal No.	Color of Wire	Signal Name
132	B	GND2
135	LG	BAT BCM FUSE
138	B	GND1
142	W	BAT-POWER F/L

Connector No.	M11
Connector Name	WIRE TO WIRE
Connector Type	NST16MW-CS
Connector Color	WHITE



1	2	3	4	5	6	7		
8	9	10	11	12	13	14	15	16

Terminal No.	Color of Wire	Signal Name
10	B	-

Connector No.	M12
Connector Name	WIRE TO WIRE
Connector Type	TH40MW-NH
Connector Color	WHITE



1	2	3	4	5	6	7	8	9	10	11	12	13	14	15	16	17	18	19	20
21	22	23	24	25	26	27	28	29	30	31	32	33	34	35	36	37	38	39	40

Terminal No.	Color of Wire	Signal Name
1	W	-
2	LG	-
3	V	-
4	SB	-
5	BR	-
6	Y	-
9	BG	-
10	Y	-
11	R	-
12	G	-
15	R	- (WITH AUTOMATIC DRIVE POSITIONER)
15	W	- (WITHOUT AUTOMATIC DRIVE POSITIONER)
16	P	- (WITH AUTOMATIC DRIVE POSITIONER)
16	G	- (WITHOUT AUTOMATIC DRIVE POSITIONER)
17	BG	-
21	BR	-
22	LG	-
23	Y	-
24	L	-
25	V	-
26	SB	-

AAJIA0868GB

A  
B  
C  
D  
E  
F  
G  
H  
I  
ADP  
K  
L  
M  
N  
O  
P

# AUTOMATIC DRIVE POSITIONER SYSTEM

< WIRING DIAGRAM >

Connector No.	M73
Connector Name	TELESCOPIC MOTOR
Connector Type	NS06FW-CS
Connector Color	WHITE

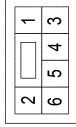

Terminal No.	Color of Wire	Signal Name
1	BR	-
2	V	-
3	Y	-
4	SB	-
5	LG	-

Connector No.	M78
Connector Name	CVT SHIFT SELECTOR
Connector Type	TH18FW-NH
Connector Color	WHITE

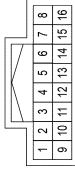

Terminal No.	Color of Wire	Signal Name
5	L	-
6	W	-

18	BG	MIRROR SENSOR (LH HORIZONTAL)
19	W	TELESCOPIC SW (BACKWARD)
20	Y	GND (SENSOR GND)
21	G	POWER SUPPLY (SENSOR FOR 9V)
22	BG	MIRROR MOTOR (RH COMMON/DOWN&RIGHT)
23	R	MIRROR MOTOR (LH VERTICAL (UP))
24	P	MIRROR MOTOR (LH HORIZONTAL (LEFT))

Connector No.	M67
Connector Name	AUTOMATIC DRIVE POSITIONER CONTROL UNIT
Connector Type	NS06FW-CS
Connector Color	WHITE

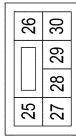

Terminal No.	Color of Wire	Signal Name
25	L	BAT (PTC)
26	V	TELESCOPIC MOTOR (BACKWARD)
27	LG	POWER SUPPLY (SENSOR)
28	SB	TILT MOTOR (DOWNWARD)
29	BR	STRG MOTOR COMMON (UPWARD/FORWARD)
30	B	GND (POWER)

Connector No.	M71
Connector Name	TILT MOTOR
Connector Type	NS06FBR-CS
Connector Color	BROWN

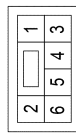

Terminal No.	Color of Wire	Signal Name
1	SB	-
2	BR	-
4	LG	-
5	L	-
6	Y	-

Connector No.	M39
Connector Name	ADP STEERING SWITCH
Connector Type	TK06FGY
Connector Color	GRAY

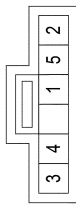

Terminal No.	Color of Wire	Signal Name
1	B	-
2	P	-
3	W	-
4	G	-
5	R	-

Connector No.	M63
Connector Name	AUTOMATIC DRIVE POSITIONER CONTROL UNIT
Connector Type	TH24FW-NH
Connector Color	WHITE



Terminal No.	Color of Wire	Signal Name
1	G	TILT SW (UPWARD)
2	LG	MIRROR SELECT SW (RH)
3	L	MIRROR SW (UPWARD)
4	V	MIRROR SW (LEFTWARD)
5	W	MIRROR SENSOR (RH VERTICAL)
6	R	MIRROR SENSOR (LH VERTICAL)
7	P	TELESCOPIC SW (FORWARD)
8	SB	UART
9	-	-
10	W	MIRROR MOTOR (RH VERTICAL)
11	G	MIRROR MOTOR (RH HORIZONTAL)
12	BG	MIRROR MOTOR (LH COMMON)
13	R	TILT SW (DOWNWARD)
14	BR	MIRROR SELECT SW (LH)
15	Y	MIRROR SW (DOWNWARD)
16	SB	MIRROR SW (RIGHTWARD)
17	P	MIRROR SENSOR (RH HORIZONTAL)

AAJIA1007GB

# AUTOMATIC DRIVE POSITIONER SYSTEM

< WIRING DIAGRAM >

Connector No.	M84
Connector Name	CIRCUIT BREAKER
Connector Type	M02FW-P-LC
Connector Color	WHITE



Terminal No.	Color of Wire	Signal Name
1	W	-
2	L	-

Connector No.	M178
Connector Name	JOINT CONNECTOR-M08
Connector Type	A06FGY
Connector Color	GRAY

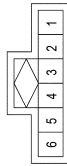

Terminal No.	Color of Wire	Signal Name
2	Y	-
3	Y	-
4	Y	-
5	Y	-
6	Y	-

Connector No.	E30
Connector Name	WIRE TO WIRE
Connector Type	TH80MW-CS16-TM4
Connector Color	WHITE

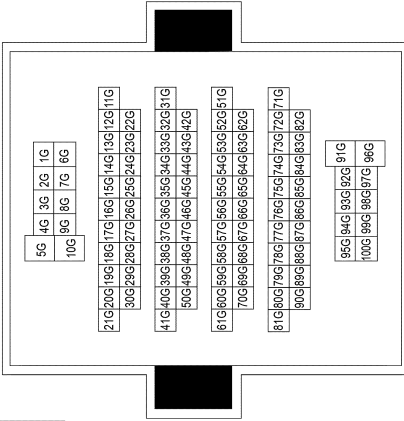

Terminal No.	Color of Wire	Signal Name
5G	P	-

Connector No.	B1
Connector Name	WIRE TO WIRE
Connector Type	TH80MDGY-CS16-TM4
Connector Color	GRAY

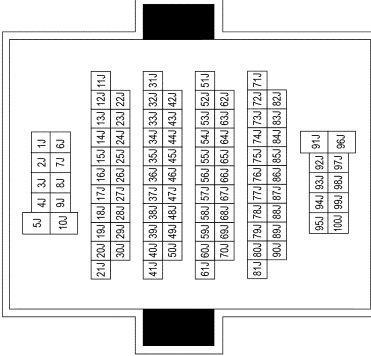

Terminal No.	Color of Wire	Signal Name
6J	V	- (WITHOUT AUTOMATIC DRIVE POSITIONER)
6J	L	- (WITH AUTOMATIC DRIVE POSITIONER)
55J	BR	-
56J	L	-
57J	LG	-
58J	V	-
59J	SB	-
60J	BR	-
61J	Y	-
70J	Y	-
73J	BR	-

Connector No.	B8
Connector Name	FRONT DOOR SWITCH LH
Connector Type	TH04FW-NH
Connector Color	WHITE

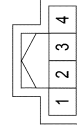

Terminal No.	Color of Wire	Signal Name
3	BR	-

A  
B  
C  
D  
E  
F  
G  
H  
I  
ADP  
K  
L  
M  
N  
O  
P

# AUTOMATIC DRIVE POSITIONER SYSTEM

< WIRING DIAGRAM >

Connector No.	B213
Connector Name	POWER SEAT SWITCH LH
Connector Type	NS10FW-CS
Connector Color	WHITE



4	3	2	1
10	9	8	7
6	5		

Terminal No.	Color of Wire	Signal Name
1	O	-
2	G	-
3	B	-
5	W	-
6	V	-
7	L	-
8	G	-
9	O	-
10	W	-

Connector No.	B201
Connector Name	WIRE TO WIRE
Connector Type	NS12MW-CS
Connector Color	WHITE



1	2	3	4	5
6	7	8	9	10
11	12			

Terminal No.	Color of Wire	Signal Name
4	R	-
11	B	-

Connector No.	B208
Connector Name	WIRE TO WIRE
Connector Type	NS12MBR-CS
Connector Color	BROWN



1	2	3	4	5
6	7	8	9	10
11	12			

Terminal No.	Color of Wire	Signal Name
1	V	-
2	SB	-
3	BR	-
8	G	-
9	W	-
10	GR	-
11	O	-
12	Y	-

Connector No.	B12
Connector Name	WIRE TO WIRE
Connector Type	NS12FW-CS
Connector Color	WHITE



5	4	3	2	1
12	11	10	9	8
7	6			

Terminal No.	Color of Wire	Signal Name
4	V	-(WITHOUT AUTOMATIC DRIVE POSITIONER)
4	L	-(WITH AUTOMATIC DRIVE POSITIONER)
11	B	-

Connector No.	B32
Connector Name	WIRE TO WIRE
Connector Type	NS12FBR-CS
Connector Color	BROWN



5	4	3	2	1
12	11	10	9	8
7	6			

Terminal No.	Color of Wire	Signal Name
1	R	-(WITHOUT AUTOMATIC DRIVE POSITIONER)
1	BR	-(WITH AUTOMATIC DRIVE POSITIONER)
2	L	-
3	SB	-(WITHOUT AUTOMATIC DRIVE POSITIONER)
3	Y	-(WITH AUTOMATIC DRIVE POSITIONER)
8	Y	-(WITHOUT AUTOMATIC DRIVE POSITIONER)
8	BR	-(WITH AUTOMATIC DRIVE POSITIONER)
9	Y	-
10	LG	-
11	V	-
12	SB	-

AAJIA0871GB

# AUTOMATIC DRIVE POSITIONER SYSTEM

< WIRING DIAGRAM >

Connector No.	B226
Connector Name	SLIDING MOTOR LH
Connector Type	7123-1460-30
Connector Color	BLACK



Terminal No.	Color of Wire	Signal Name
1	SB	-
2	B	-
3	LG	-
4	V	-
6	P	-

Connector No.	B227
Connector Name	LIFTING MOTOR LH (FRONT)
Connector Type	7123-1460-30
Connector Color	BLACK



Terminal No.	Color of Wire	Signal Name
1	W	-
2	B	-
3	SB	-
4	O	-
6	GR	-

Connector No.	B223
Connector Name	DRIVER SEAT CONTROL UNIT
Connector Type	NS12FW-CS
Connector Color	WHITE

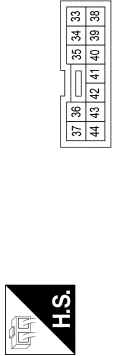

Terminal No.	Color of Wire	Signal Name
33	-	-
34	O	FRONT LIFTER MOTOR (DOWNWARD)
35	Y	RECLINER MOTOR (FORWARD)
36	V	SLIDE MOTOR (BACKWARD)
37	R	BAT (PTC)
38	-	-
39	B	GND
40	G	REAR LIFTER MOTOR (DOWNWARD)
41	L	REAR LIFTER MOTOR (UPWARD)
42	GR	FRONT LIFTER MOTOR (UPWARD)
43	W	RECLINER MOTOR (BACKWARD)
44	P	-SLIDE MOTOR (FORWARD)

Connector No.	B225
Connector Name	RECLINING MOTOR LH
Connector Type	7123-1460-30
Connector Color	BLACK



Terminal No.	Color of Wire	Signal Name
1	P	-
2	B	-
3	SB	-
4	Y	-
6	W	-

Connector No.	B222
Connector Name	DRIVER SEAT CONTROL UNIT
Connector Type	TH32FW-NH
Connector Color	WHITE

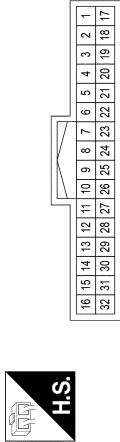

Terminal No.	Color of Wire	Signal Name
1	-	-
2	-	-
3	-	-
4	-	-
5	SB	POWER SUPPLY (ENCODER)
6	G	REAR LIFTER SW (DOWNWARD)
7	O	FRONT LIFTER SW (DOWNWARD)
8	W	RECLINER SW (BACKWARD)
9	V	SLIDE SW (BACKWARD)
10	G	IND 2
11	GR	ADDRESS 2
12	V	PULSE (TELESCOPIC)
13	P	PULSE (RECLINER)
14	-	-
15	BR	URAT (TX/RX)
16	L	CAN-H
17	-	-
18	-	-
19	-	-
20	-	-
21	Y	SET SW
22	O	REAR LIFTER SW (UPWARD)
23	G	FRONT LIFTER SW (UPWARD)
24	W	RECLINER SW (FORWARD)
25	L	SLIDE SW (FORWARD)
26	W	IND 1
27	O	ADDRESS 1
28	SB	PULSE(TILT)
29	GR	PULSE (REAR LIFTER)
30	W	PULSE (FRONT LIFTER)
31	LG	PULSE (SLIDE)
32	P	CAN-L

AAJIA0872GB

A B C D E F G H I J K L M N O P

ADP

# AUTOMATIC DRIVE POSITIONER SYSTEM

< WIRING DIAGRAM >

Connector No.	D13
Connector Name	SEAT MEMORY SWITCH
Connector Type	TH16FW-NH
Connector Color	WHITE

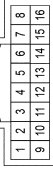

Terminal No.	Color of Wire	Signal Name
7	SB	-
9	L	-
10	V	-
11	Y	-
12	LG	-
15	BR	-
16	B	-

Connector No.	D19
Connector Name	DOOR MIRROR REMOTE CONTROL SWITCH (WITH AUTOMATIC DRIVE POSITIONER)
Connector Type	TH16FGY-NH
Connector Color	GRAY

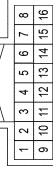

Terminal No.	Color of Wire	Signal Name
1	Y	-
3	SB	-
4	LG	-
9	V	-
12	L	-
15	B	-
16	BR	-

2	L	-
3	BR	-
4	SB	-
5	LG	-
6	Y	-
9	V	-
10	Y	-
11	LG	-
12	BR	-
15	R	- (WITH AUTOMATIC DRIVE POSITIONER)
15	BG	- (WITHOUT AUTOMATIC DRIVE POSITIONER)
16	W	- (WITH AUTOMATIC DRIVE POSITIONER)
16	P	- (WITHOUT AUTOMATIC DRIVE POSITIONER)
17	W	- (WITH AUTOMATIC DRIVE POSITIONER)
17	P	- (WITHOUT AUTOMATIC DRIVE POSITIONER)
21	SB	-
22	LG	-
23	L	-
24	BR	-
25	V	-
26	Y	-

Connector No.	D12
Connector Name	DOOR MIRROR LH (WITH AUTOMATIC DRIVE POSITIONER)
Connector Type	TH24MW-NH
Connector Color	WHITE



Terminal No.	Color of Wire	Signal Name
10	P	-
11	W	-
12	R	-
21	Y	-
22	BR	-
23	V	-
24	LG	-

Connector No.	B228
Connector Name	LIFTING MOTOR LH (REAR)
Connector Type	7123-1460-30
Connector Color	BLACK



Terminal No.	Color of Wire	Signal Name
1	SB	-
2	B	-
3	GR	-
4	G	-
6	L	-

Connector No.	D1
Connector Name	WIRE TO WIRE
Connector Type	NS16FW-CS
Connector Color	WHITE

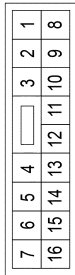

Terminal No.	Color of Wire	Signal Name
10	B	-

Connector No.	D2
Connector Name	WIRE TO WIRE
Connector Type	TH40FW-NH
Connector Color	WHITE

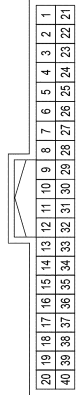

Terminal No.	Color of Wire	Signal Name
1	V	-

AAJIA0873GB



# AUTOMATIC DRIVE POSITIONER SYSTEM

< WIRING DIAGRAM >

A  
B  
C  
D  
E  
F  
G  
H  
I  
K  
L  
M  
N  
O  
P

Connector No.	D102
Connector Name	WIRE TO WIRE
Connector Type	TH24FW-NH
Connector Color	WHITE

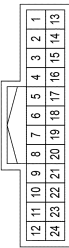

Terminal No.	Color of Wire	Signal Name
1	Y	-
2	L	-
3	BR	-
4	V	-
7	P	-
8	W	-
9	R	-

Connector No.	D114
Connector Name	DOOR MIRROR RH (WITH AUTOMATIC DRIVE POSITIONER)
Connector Type	TH24MW-NH
Connector Color	WHITE

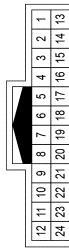

Terminal No.	Color of Wire	Signal Name
10	R	-
11	W	-
12	P	-
21	L	-
22	V	-
23	Y	-
24	BR	-

AAJIA0874GB

ADP

# DIAGNOSIS AND REPAIR WORK FLOW

< BASIC INSPECTION >

## BASIC INSPECTION

### DIAGNOSIS AND REPAIR WORK FLOW

Work Flow

INFOID:000000012246470

WORK FLOW

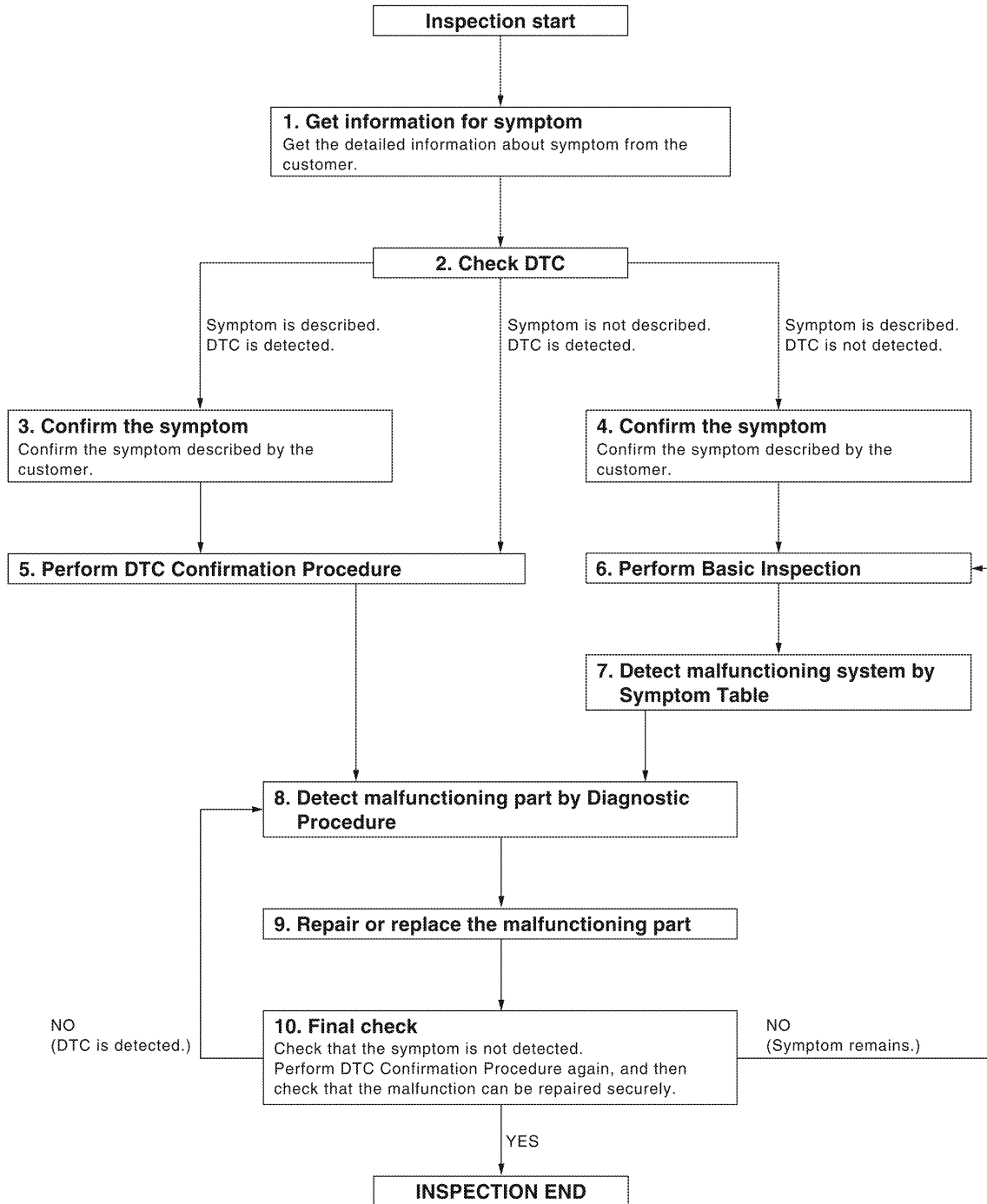

ALKIA0538GB

DETAILED FLOW

Revision: October 2015

ADP-50

2016 Maxima NAM

# DIAGNOSIS AND REPAIR WORK FLOW

< BASIC INSPECTION >

---

## 1. GET INFORMATION FOR SYMPTOM

Get the detailed information from the customer about the symptom (the condition and the environment when the incident/malfunction occurred).

>> GO TO 2.

---

## 2. CHECK DTC

### ⓂCONSULT

Check "Self Diagnostic Result" mode of "AUTO DRIVE POS.". Refer to [ADP-32. "DTC Index"](#).

Is any symptom described and is any DTC displayed?

Symptom is described, DTC is displayed.>> GO TO 3.

Symptom is not described, DTC is displayed.>> GO TO 5.

Symptom is described, DTC is not displayed.>> GO TO 4.

---

## 3. CONFIRM THE SYMPTOM

Try to confirm the symptom described by the customer.

>> GO TO 5.

---

## 4. CONFIRM THE SYMPTOM

Try to confirm the symptom described by the customer.

>> GO TO 6.

---

## 5. PERFORM DTC CONFIRMATION PROCEDURE

Perform the confirmation procedure for the detected DTC.

Is the DTC displayed?

YES >> GO TO 8.

NO >> Check intermittent incident. Refer to [GI-41. "Intermittent Incident"](#).

---

## 6. PERFORM BASIC INSPECTION

Isolate the malfunctioning point with a basic inspection.

>> GO TO 7.

---

## 7. DETECT MALFUNCTIONING SYSTEM BY SYMPTOM TABLE

Detect malfunctioning system according to SYMPTOM DIAGNOSIS based on the confirmed symptom in step 4 and determine the trouble diagnosis order based on possible causes and symptom.

>> GO TO 8.

---

## 8. DETECT MALFUNCTIONING PART BY DIAGNOSTIC PROCEDURE

Isolate the malfunctioning point by performing the diagnosis procedure relevant to the symptom during the component diagnosis.

>> GO TO 9.

---

## 9. REPAIR OR REPLACE

Repair or replace the malfunctioning part.

>> GO TO 10.

---

## 10. FINAL CHECK

Perform the DTC confirmation procedure (if DTC is detected) or component function check (if no DTC is detected) again, and then check that the malfunction can be repaired securely.

A  
B  
C  
D  
E  
F  
G  
H  
I  
K  
L  
M  
N  
O  
P

ADP

## DIAGNOSIS AND REPAIR WORK FLOW

< BASIC INSPECTION >

---

Are all malfunctions corrected?

YES >> Inspection End.

Symptom is detected.>> GO TO 6.

DTC is detected.>> GO TO 8.

# INSPECTION AND ADJUSTMENT

< BASIC INSPECTION >

## INSPECTION AND ADJUSTMENT

### ADDITIONAL SERVICE WHEN REMOVING BATTERY NEGATIVE TERMINAL

#### ADDITIONAL SERVICE WHEN REMOVING BATTERY NEGATIVE TERMINAL : Work Procedure

INFOID:000000012246471

##### 1.SYSTEM INITIALIZATION

Perform system initialization. Refer to [ADP-54, "SYSTEM INITIALIZATION : Work Procedure"](#).

>> GO TO 2.

##### 2.MEMORY STORAGE

Perform memory storage. Refer to [ADP-54, "MEMORY STORING : Work Procedure"](#).

>> GO TO 3.

##### 3.LINKING KEY FOB TO METER DISPLAY FUNCTION STORAGE

Perform linking key fob to meter display function storage. Refer to [ADP-55, "LINKING KEY FOB TO THE METER DISPLAY : Work Procedure"](#).

>> GO TO 4.

##### 4.SYSTEM SETTING

Perform system setting. Refer to [ADP-56, "SYSTEM SETTING : Work Procedure"](#).

>> Inspection End.

### ADDITIONAL SERVICE WHEN REPLACING CONTROL UNIT

#### ADDITIONAL SERVICE WHEN REPLACING CONTROL UNIT : Description

INFOID:000000012246472

Each function is reset to the following condition when the driver seat control unit is replaced.

Function	Condition	Procedure
Memory (Seat, steering, mirror)	Erased	Perform storing
Entry/exit assist	ON	Perform initialization
		Set slide amount*1
Linking a key fob to meter display	Erased	Perform initialization
		Perform storing

\*1: Default value is 40 mm.

#### NOTE:

Notice that disconnecting the battery when detected DTC is present will erase the DTC memory.

#### ADDITIONAL SERVICE WHEN REPLACING CONTROL UNIT : Work Procedure

INFOID:000000012246473

##### 1.SYSTEM INITIALIZATION

Perform system initialization. Refer to [ADP-54, "SYSTEM INITIALIZATION : Work Procedure"](#).

>> GO TO 2.

##### 2.MEMORY STORAGE

Perform memory storage. Refer to [ADP-54, "MEMORY STORING : Work Procedure"](#).

A  
B  
C  
D  
E  
F  
G  
H  
I  
K  
L  
M  
N  
O  
P

ADP

# INSPECTION AND ADJUSTMENT

## < BASIC INSPECTION >

---

>> GO TO 3.

### 3. LINKING KEY FOB TO METER DISPLAY FUNCTION STORAGE

Perform linking key fob to meter display function storage. Refer to [ADP-55. "LINKING KEY FOB TO THE METER DISPLAY : Work Procedure"](#).

>> GO TO 4.

### 4. SYSTEM SETTING

Perform system setting. Refer to [ADP-56. "SYSTEM SETTING : Work Procedure"](#).

>> Inspection End.

## SYSTEM INITIALIZATION

### SYSTEM INITIALIZATION : Description

INFOID:0000000012246474

Always perform the initialization when the battery terminal is disconnected or the driver seat control unit is replaced.

The entry/exit assist function will not operate normally if no initialization is performed.

### SYSTEM INITIALIZATION : Work Procedure

INFOID:0000000012246475

#### INITIALIZATION PROCEDURE

##### 1. CHOOSE METHOD

There are two initialization methods.

Which method do you use?

With door switch >> GO TO 2.

With vehicle speed >> GO TO 4.

##### 2. STEP A-1

Turn ignition switch from ACC to OFF position.

>> GO TO 3.

##### 3. STEP A-2

Driver door switch is ON (open) → OFF (close) → ON (open).

>> Inspection End.

##### 4. STEP B-1

Drive the vehicle at more than 25 km/h (16 MPH).

>> Inspection End.

## MEMORY STORING

### MEMORY STORING : Description

INFOID:0000000012246476

Always perform the memory storage when the battery terminal is disconnected or the driver seat control unit is replaced. The memory function will not operate normally if no memory storage is performed.

### MEMORY STORING : Work Procedure

INFOID:0000000012246477

#### Memory Storage Procedure

Two positions for the driver seat, steering column and outside mirror can be stored for memory operation by the following procedure:

##### 1. STEP 1

# INSPECTION AND ADJUSTMENT

## < BASIC INSPECTION >

Check the following conditions.

- Ignition switch: ON
- CVT shift selector: P (Park) position

>> GO TO 2.

### 2.STEP 2

Adjust driver seat, steering column and outside mirror position manually.

>> GO TO 3.

### 3.STEP 3

1. Push set switch.

**NOTE:**

- Memory indicator for which driver seat position is already retained in memory is illuminated for 5 seconds.
- Memory indicator for which driver seat position is not retained in memory is illuminated for 0.5 seconds.

2. Push the memory switch (1 or 2) for at least 1 second within 5 seconds after pushing the set switch.

**NOTE:**

- To enter driver seat positions into blank memory, memory indicator will be turned on for 5 seconds.
- To modify driver seat positions, memory indicator will be turned OFF for 0.5 seconds then turned ON for 5 seconds.

**NOTE:**

If memory is stored in the same memory switch, the previous memory will be deleted.

>> GO TO 4.

### 4.STEP 4

Confirm the operation of each part with memory operation.

>> Inspection End.

## LINKING KEY FOB TO THE METER DISPLAY

### LINKING KEY FOB TO THE METER DISPLAY : Description

INFOID:000000012246478

Always perform when the battery terminal is disconnected or the driver seat control unit is replaced. Linking key fob to the meter display will not operate normally if no memory storage is performed.

### LINKING KEY FOB TO THE METER DISPLAY : Work Procedure

INFOID:000000012246479

#### Linking Key Fob To Meter Display Function Procedure

Performing the following operation associates the registered driving position with Intelligent Key. When driver door unlock operation is performed by Intelligent Key or driver door request switch, display of the registered driving position and turnout operation can be performed.

### 1.STEP 1

Check the following conditions:

- Ignition switch: ON
- Initialization: done
- Driving position: registered

>> GO TO 2.

### 2.STEP 2

1. Switch ignition from ON to OFF (ADP memory automatically at the ignition OFF timing).

>> GO TO 3.

A  
B  
C  
D  
E  
F  
G  
H  
I  
K  
L  
M  
N  
O  
P

ADP

# INSPECTION AND ADJUSTMENT

< BASIC INSPECTION >

## 3. STEP 3

Confirm the operation of each part with memory operation and linking a key fob to the meter display operation.

>> Inspection End.

## SYSTEM SETTING

### SYSTEM SETTING : Description

INFOID:000000012246480

The settings of the automatic drive positioner system can be changed using CONSULT, the display unit in the center of the instrument panel and the set switch. Always check the settings before and after disconnecting the battery terminal or replacing driver seat control unit.

### Setting Change

x: Applicable

Item	Content	CONSULT	Set switch	Factory setting
Amount of seat sliding for entry/exit assist	The amount of seat sliding for entry/exit assist can be selected from 3 items. [40 mm/80 mm/150 mm]	x	—	40 mm
Entry/exit assist (seat)	Entry/exit assist (seat) can be selected: ON (operated) – OFF (not operated)	x	x	ON
Entry/exit assist (steering column)	Entry/exit assist (steering column) can be selected: ON (operated) – OFF (not operated)	x		ON

### SYSTEM SETTING : Work Procedure

INFOID:000000012246481

#### 1. CHOOSE METHOD

There are two setting methods.

Which method do you choose?

With CONSULT>> GO TO 2.

With set switch>> GO TO 4.

#### 2. WITH CONSULT - STEP 1

 CONSULT

Select "Work support" mode of "AUTO DRIVE POS."

>> GO TO 3.

#### 3. WITH CONSULT - STEP 2

 CONSULT

1. Select "EXIT SEAT SLIDE SETTING", or "EXIT TILT SETTING" then touch display to change between ON and OFF.
  - EXIT SEAT SLIDE SETTING: Entry/exit assist (seat)
  - EXIT TILT SETTING: Entry/exit assist (steering column)
2. Select "SEAT SLIDE VOLUME SET" and touch either "40 mm", "80 mm", or "150 mm".
3. Then touch "OK".

>> Inspection End.

#### 4. WITH SET SWITCH - STEP 1

Turn ignition switch OFF.

>> GO TO 5.

#### 5. WITH SET SWITCH - STEP 2



# INSPECTION AND ADJUSTMENT

## < BASIC INSPECTION >

---

Push set switch and hold for more than 10 seconds then confirm blinking of the memory switch indicator.

- Entry/exit assist (seat/steering column) is ON: Memory switch indicator blinks two times.
- Entry/exit assist (seat/steering column) is OFF: Memory switch indicator blinks once.

A

>> Inspection End.

B

C

D

E

F

G

H

I

ADP

K

L

M

N

O

P

# U1000 CAN COMM CIRCUIT

< DTC/CIRCUIT DIAGNOSIS >

## DTC/CIRCUIT DIAGNOSIS

### U1000 CAN COMM CIRCUIT

#### DTC Description

INFOID:0000000012246482

#### DTC DETECTION LOGIC

DTC No.	CONSULT screen terms (Trouble diagnosis content)	DTC Detection Condition	
		Diagnosis condition	When ignition switch is ON.
U1000	CAN COMM CIRCUIT (CAN communication circuit)	Signal (terminal)	—
		Threshold	—
		Diagnosis delay time	2 seconds or more

#### POSSIBLE CAUSE

CAN communication system

#### FAIL-SAFE

—

#### DTC CONFIRMATION PROCEDURE

##### 1. STEP 1

Turn ignition switch ON and wait at least 2 seconds.

>> GO TO 2.

##### 2. STEP 2

#### ⓑCONSULT

Check "Self Diagnostic Result" mode of "AUTO DRIVE POS.".

Is the DTC detected?

YES >> Perform diagnosis procedure. Refer to [ADP-58, "Diagnosis Procedure"](#).

NO-1 >> To check malfunction symptom before repair: Refer to [GI-41, "Intermittent Incident"](#).

NO-2 >> Confirmation after repair: Inspection End.

#### Diagnosis Procedure

INFOID:0000000012246483

##### 1. SELF DIAGNOSTIC RESULT

#### ⓑCONSULT

1. Turn ignition switch ON and wait for 2 seconds or more.

2. Check "Self Diagnostic Result" mode of "AUTO DRIVE POS.".

3. Check DTC.

Is DTC "U1000" displayed?

YES >> Refer to [LAN-17, "Trouble Diagnosis Flow Chart"](#).

NO >> GO TO 2.

##### 2. CHECK INTERMITTENT INCIDENT

Refer to [GI-41, "Intermittent Incident"](#).

>> Inspection End.

# U1010 CONTROL UNIT (CAN)

< DTC/CIRCUIT DIAGNOSIS >

## U1010 CONTROL UNIT (CAN)

### DTC Description

INFOID:000000012246484

### DTC DETECTION LOGIC

DTC No.	CONSULT screen terms (Trouble diagnosis content)	DTC Detection Condition	
		Diagnosis condition	When ignition switch is ON.
U1010	CONTROL UNIT (Control unit)	Signal (terminal)	—
		Threshold	—
		Diagnosis delay time	2 seconds or more

### POSSIBLE CAUSE

Driver seat control unit

### FAIL-SAFE

—

### Diagnosis Procedure

INFOID:000000012246485

#### 1. REPLACE DRIVER SEAT CONTROL UNIT

When DTC [U1010] is detected, replace driver seat control unit.

>> Replace driver seat control unit. Refer to [ADP-130. "Removal and Installation"](#).

A  
B  
C  
D  
E  
F  
G  
H  
I  
K  
L  
M  
N  
O  
P

ADP

# B2112 SLIDING MOTOR

< DTC/CIRCUIT DIAGNOSIS >

## B2112 SLIDING MOTOR

### DTC Description

INFOID:000000012246486

### DTC DETECTION LOGIC

DTC No.	CONSULT screen terms (Trouble diagnosis content)	DTC Detection Condition	
B2112	SEAT SLIDE (Seat slide)	Diagnosis condition	When ignition switch is ON.
		Signal (terminal)	Sliding motor LH circuit (terminals 4 and 6)
		Threshold	Approx. 0V
		Diagnosis delay time	0.1 seconds or more

### POSSIBLE CAUSE

- Driver seat control unit
- Slide motor harness is shorted

### FAIL-SAFE

Only manual functions, except seat sliding, operate normally.

### DTC CONFIRMATION PROCEDURE

#### 1.SELF-DIAGNOSIS WITH AUTOMATIC DRIVE POSITIONER CONTROL UNIT

##### ⓅCONSULT

1. Turn ignition switch ON.
2. Check "Self Diagnostic Result" mode of "AUTO DRIVE POS."
3. Check DTC.

##### Is the DTC detected?

- YES >> Perform diagnosis procedure. Refer to [ADP-60, "Diagnosis Procedure"](#).  
NO-1 >> To check malfunction symptom before repair: Refer to [GI-41, "Intermittent Incident"](#).  
NO-2 >> Confirmation after repair: Inspection End.

### Diagnosis Procedure

INFOID:000000012246487

Regarding Wiring Diagram information, refer to [ADP-38, "Wiring Diagram"](#).

#### 1.SELF DIAGNOSTIC RESULT

##### ⓅCONSULT

1. Turn ignition switch ON.
2. Check "Self Diagnostic Result" of "AUTO DRIVE POS."
3. Erase the DTC.
4. Perform DTC confirmation procedure. Refer to [ADP-60, "DTC Description"](#).

##### Is the DTC displayed again?

- YES >> GO TO 2.  
NO >> Check intermittent incident. Refer to [GI-41, "Intermittent Incident"](#).

#### 2.CHECK SLIDING MOTOR LH CIRCUIT (POWER SHORT)

1. Turn ignition switch OFF.
2. Disconnect sliding motor LH and driver seat control unit connector.
3. Check voltage between sliding motor LH harness connector and ground.

# B2112 SLIDING MOTOR

## < DTC/CIRCUIT DIAGNOSIS >

(+)		(-)	Voltage (Approx.)
Sliding motor LH			
Connector	Terminals		
B226	4	Ground	0V
	6		

Is the inspection result normal?

YES >> GO TO 3.

NO >> Repair or replace harness or connector.

### 3. CHECK DRIVER SEAT CONTROL UNIT OUTPUT SIGNAL

1. Connect driver seat control unit connector.
2. Check voltage between driver seat control unit harness connector and ground.

(+)		(-)	Voltage (V) (Approx.)
Driver seat control unit			
Connector	Terminals		
B223	36	Ground	0V
	44		

Is the inspection result normal?

YES >> GO TO 4.

NO >> Replace driver seat control unit. Refer to [ADP-130, "Removal and Installation"](#).

### 4. CHECK INTERMITTENT INCIDENT

Refer to [GI-41, "Intermittent Incident"](#).

>> Inspection End.

ADP

# B2113 RECLINING MOTOR

< DTC/CIRCUIT DIAGNOSIS >

## B2113 RECLINING MOTOR

### DTC Description

INFOID:000000012246488

### DTC DETECTION LOGIC

DTC No.	CONSULT screen terms (Trouble diagnosis content)	DTC Detection Condition	
B2113	SEAT RECLINING (Seat reclining)	Diagnosis condition	When ignition switch is ON.
		Signal (terminal)	Reclining motor LH circuit (terminals 4 and 6)
		Threshold	Approx. 0V
		Diagnosis delay time	0.1 seconds or more

### POSSIBLE CAUSE

- Driver seat control unit
- Reclining motor harness is shorted

### FAIL-SAFE

Only manual functions, except seat reclining, operate normally.

### DTC CONFIRMATION PROCEDURE

#### 1. SELF-DIAGNOSIS WITH AUTOMATIC DRIVE POSITIONER CONTROL UNIT

##### ⓅCONSULT

1. Turn ignition switch ON.
2. Check "Self Diagnostic Result" mode of "AUTO DRIVE POS."
3. Check DTC.

##### Is the DTC detected?

- YES >> Perform diagnosis procedure. Refer to [ADP-62, "Diagnosis Procedure"](#).  
NO-1 >> To check malfunction symptom before repair: Refer to [GI-41, "Intermittent Incident"](#).  
NO-2 >> Confirmation after repair: Inspection End.

### Diagnosis Procedure

INFOID:000000012246489

Regarding Wiring Diagram information, refer to [ADP-38, "Wiring Diagram"](#).

#### 1. PERFORM DTC CONFIRMATION PROCEDURE

##### ⓅCONSULT

1. Turn ignition switch ON.
2. Check "Self Diagnostic Result" mode of "AUTO DRIVE POS."
3. Erase the DTC.
4. Perform DTC confirmation procedure. Refer to [ADP-62, "DTC Description"](#).

##### Is the DTC displayed again?

- YES >> GO TO 2.  
NO >> Check intermittent incident. Refer to [GI-41, "Intermittent Incident"](#).

#### 2. CHECK RECLINING MOTOR LH CIRCUIT (POWER SHORT)

1. Turn ignition switch OFF.
2. Disconnect reclining motor LH and driver seat control unit connector.
3. Check voltage between reclining motor LH harness connector and ground.

# B2113 RECLINING MOTOR

## < DTC/CIRCUIT DIAGNOSIS >

(+)		(-)	Voltage (V) (Approx.)
Reclining motor LH			
Connector	Terminals	Ground	0
B225	4		
	6		

Is the inspection result normal?

YES >> GO TO 3.

NO >> Repair or replace harness or connector.

### 3. CHECK DRIVER SEAT CONTROL UNIT OUTPUT SIGNAL

1. Connect driver seat control unit connector.
2. Check voltage between driver seat control unit harness connector and ground.

(+)		(-)	Voltage (V) (Approx.)
Driver seat control unit			
Connector	Terminals	Ground	0
B223	35		
	43		

Is the inspection result normal?

YES >> GO TO 4.

NO >> Replace driver seat control unit. Refer to [ADP-130, "Removal and Installation"](#).

### 4. CHECK INTERMITTENT INCIDENT

Refer to [GI-41, "Intermittent Incident"](#).

>> Inspection End.

ADP

# B2116 TILT MOTOR

< DTC/CIRCUIT DIAGNOSIS >

## B2116 TILT MOTOR

### DTC Description

INFOID:000000012246490

### DTC DETECTION LOGIC

DTC No.	CONSULT screen terms (Trouble diagnosis content)	DTC Detection Condition	
B2116	STEERING TILT (Steering tilt)	Diagnosis condition	When ignition switch is ON.
		Signal (terminal)	Steering tilt motor circuit (terminals 1 and 2)
		Threshold	Approx. 0V
		Diagnosis delay time	0.1 seconds or more

### POSSIBLE CAUSE

- Automatic drive positioner control unit
- Tilt motor harness is shorted

### FAIL-SAFE

Only manual functions, except steering tilt, operate normally.

### DTC CONFIRMATION PROCEDURE

#### 1. SELF DIAGNOSIS WITH AUTOMATIC DRIVE POSITIONER CONTROL UNIT

##### ⓅCONSULT

1. Turn ignition switch ON.
2. Check "Self Diagnostic Result" mode of "AUTO DRIVE POS."
3. Check DTC.

##### Is the DTC detected?

- YES >> Perform diagnosis procedure. Refer to [ADP-64, "Diagnosis Procedure"](#).  
NO-1 >> To check malfunction symptom before repair: Refer to [GI-41, "Intermittent Incident"](#).  
NO-2 >> Confirmation after repair: Inspection End.

### Diagnosis Procedure

INFOID:000000012246491

Regarding Wiring Diagram information, refer to [ADP-38, "Wiring Diagram"](#).

#### 1. PERFORM DTC CONFIRMATION PROCEDURE

##### ⓅCONSULT

1. Turn ignition switch ON.
2. Check "Self Diagnostic Result" mode of "AUTO DRIVE POS."
3. Erase the DTC.
4. Perform DTC confirmation procedure. Refer to [ADP-64, "DTC Description"](#).

##### Is the DTC displayed again?

- YES >> GO TO 2.  
NO >> Check intermittent incident. Refer to [GI-41, "Intermittent Incident"](#).

#### 2. CHECK TILT MOTOR CIRCUIT (POWER SHORT)

1. Turn ignition switch OFF.
2. Disconnect automatic drive positioner control unit and tilt motor connector.
3. Check voltage between tilt motor harness connector and ground.



## B2116 TILT MOTOR

### < DTC/CIRCUIT DIAGNOSIS >

(+)		(-)	Voltage (V) (Approx.)
Tilt motor			
Connector	Terminals		
M71	1	Ground	0V
	2		

Is the inspection result normal?

YES >> GO TO 3.

NO >> Repair or replace harness or connector.

### 3. CHECK AUTOMATIC DRIVE POSITIONER CONTROL UNIT OUTPUT SIGNAL

1. Connect automatic drive positioner control unit connector.
2. Check voltage between automatic drive positioner control unit harness connector and ground.

(+)		(-)	Voltage (V) (Approx.)
Automatic drive positioner control unit			
Connector	Terminals		
M67	28	Ground	0V
	29		

Is the inspection result normal?

YES >> Check intermittent incident. Refer to [GI-41. "Intermittent Incident"](#).

NO >> Replace automatic drive positioner control unit. Refer to [ADP-130. "Removal and Installation"](#).

A  
B  
C  
D  
E  
F  
G  
H  
I  
K  
L  
M  
N  
O  
P

ADP

# B2128 UART COMMUNICATION LINE

< DTC/CIRCUIT DIAGNOSIS >

## B2128 UART COMMUNICATION LINE

### DTC Description

INFOID:000000012246492

### DTC DETECTION LOGIC

DTC No.	CONSULT screen terms (Trouble diagnosis content)	DTC Detection Condition	
B2128	UART COMM (Universal asynchronous re- ceiver transmitter communi- cation)	Diagnosis condition	When ignition switch is ON.
		Signal (terminal)	—
		Threshold	—
		Diagnosis delay time	—

### POSSIBLE CAUSE

- UART communication line  
(UART communication line is open or shorted)
- Driver seat control unit
- Automatic drive positioner control unit

### FAIL-SAFE

Only manual functions, except door mirror, operate normally.

### DTC CONFIRMATION PROCEDURE

#### 1. SELF-DIAGNOSIS WITH AUTOMATIC DRIVE POSITIONER CONTROL UNIT

##### ⓂCONSULT

1. Turn ignition switch ON.
2. Check "Self Diagnostic Result" mode of "AUTO DRIVE POS."
3. Check DTC.

##### Is the DTC detected?

- YES >> Perform diagnosis procedure. Refer to [ADP-66, "Diagnosis Procedure"](#).  
NO-1 >> To check malfunction symptom before repair: Refer to [GI-41, "Intermittent Incident"](#).  
NO-2 >> Confirmation after repair: Inspection End.

### Diagnosis Procedure

INFOID:000000012246493

Regarding Wiring Diagram information, refer to [ADP-38, "Wiring Diagram"](#).

#### 1. PERFORM DTC CONFIRMATION PROCEDURE

##### ⓂCONSULT

1. Turn ignition switch ON.
2. Check "Self Diagnostic Result" mode of "AUTO DRIVE POS."
3. Erase the DTC.
4. Perform DTC confirmation procedure. Refer to [ADP-66, "DTC Description"](#).

##### Is the DTC displayed again?

- YES >> GO TO 2.  
NO >> Check intermittent incident. Refer to [GI-41, "Intermittent Incident"](#).

#### 2. CHECK UART COMMUNICATION LINE CONTINUITY

1. Turn ignition switch OFF.
2. Disconnect driver seat control unit and automatic drive positioner control unit.
3. Check continuity between driver seat control unit harness connector and automatic drive positioner control unit harness connector.

## B2128 UART COMMUNICATION LINE

< DTC/CIRCUIT DIAGNOSIS >

Driver seat control unit		Automatic drive positioner control unit		Continuity
Connector	Terminal	Connector	Terminal	
B222	15	M63	8	Yes

4. Check continuity between driver seat control unit harness connector and ground.

Driver seat control unit		Ground	Continuity
Connector	Terminal		
B222	15		No

Is the inspection result normal?

- YES >> Check intermittent incident. Refer to [GI-41, "Intermittent Incident"](#).
- NO >> Repair or replace harness.

A  
B  
C  
D  
E  
F  
G  
H  
I  
K  
L  
M  
N  
O  
P

ADP

# B2130 EEPROM

< DTC/CIRCUIT DIAGNOSIS >

## B2130 EEPROM

### DTC Description

INFOID:000000012246494

### DTC DETECTION LOGIC

DTC No.	CONSULT screen terms (Trouble diagnosis content)	DTC Detection Condition	
		Diagnosis condition	When ignition switch is ON.
B2130	EEPROM (EEPROM malfunction)	Signal (terminal)	—
		Threshold	—
		Diagnosis delay time	—

### POSSIBLE CAUSE

Driver seat control unit

### FAIL-SAFE

Only manual functions operate normally.

### DTC CONFIRMATION PROCEDURE

#### 1. SELF-DIAGNOSIS WITH AUTOMATIC DRIVE POSITIONER CONTROL UNIT

##### CONSULT

1. Turn ignition switch ON.
2. Check "Self Diagnostic Result" mode of "AUTO DRIVE POS."
3. Check DTC.

##### Is the DTC detected?

YES >> Perform diagnosis procedure. Refer to [ADP-68, "Diagnosis Procedure"](#).

NO-1 >> To check malfunction symptom before repair: Refer to [GI-41, "Intermittent Incident"](#).

NO-2 >> Confirmation after repair: Inspection End.

### Diagnosis Procedure

INFOID:000000012246495

#### 1. PERFORM DTC CONFIRMATION PROCEDURE

##### CONSULT

1. Turn ignition switch ON.
2. Check "Self Diagnostic Result" mode of "AUTO DRIVE POS."
3. Erase the DTC.
4. Perform DTC confirmation procedure. Refer to [ADP-68, "DTC Description"](#).

##### Is the DTC displayed again?

YES >> Replace driver seat control unit. Refer to [ADP-130, "Removal and Installation"](#).

NO >> GO TO 2.

#### 2. CHECK INTERMITTENT INCIDENT

Refer to [GI-41, "Intermittent Incident"](#).

>> Inspection End.

# POWER SUPPLY AND GROUND CIRCUIT

< DTC/CIRCUIT DIAGNOSIS >

## POWER SUPPLY AND GROUND CIRCUIT

BCM

BCM : Diagnosis Procedure

INFOID:000000012323194

Regarding Wiring Diagram information, refer to [BCS-56. "Wiring Diagram"](#).

### 1. CHECK FUSE AND FUSIBLE LINK

Check if the following BCM fuses or fusible link are blown.

Signal name	Fuse and fusible link No.
Fusible link battery power	I (40A)
BCM battery fuse	1 (10A)

Is the fuse or fusible link blown?

- YES >> Replace the blown fuse or fusible link after repairing the affected circuit.  
NO >> GO TO 2.

### 2. CHECK POWER SUPPLY CIRCUIT

1. Turn ignition switch OFF.
2. Disconnect BCM connector M17.
3. Check voltage between BCM harness connector M17 and ground.

Terminals		Voltage (Approx.)
(+)	(-)	
BCM		Ground
Connector	Terminal	
M17	135	
	142	Battery voltage

Is the measurement normal?

- YES >> GO TO 3.  
NO >> Repair or replace harness.

### 3. CHECK GROUND CIRCUIT

Check continuity between BCM harness connector M17 and ground.

BCM		Ground	Continuity
Connector	Terminal		
M17	138		Yes
	132		

Is the inspection result normal?

- YES >> Inspection End.  
NO >> Repair or replace harness.

## DRIVER SEAT CONTROL UNIT

DRIVER SEAT CONTROL UNIT : Diagnosis Procedure

INFOID:000000012246497

#### NOTE:

Do not disconnect the battery negative terminal and the driver seat control unit connector until DTC is confirmed with CONSULT.

# POWER SUPPLY AND GROUND CIRCUIT

## < DTC/CIRCUIT DIAGNOSIS >

Regarding Wiring Diagram information, refer to [ADP-38. "Wiring Diagram"](#).

### 1. CHECK FUSE

Check that the following fusible link is not blown.

Signal name	Fusible link No.
Battery power supply	I (40 A)

Is the inspection result normal?

YES >> GO TO 2.

NO >> Replace the blown fusible link after repairing the affected circuit.

### 2. CHECK POWER SUPPLY CIRCUIT

1. Turn ignition switch OFF.
2. Disconnect driver seat control unit.
3. Check voltage between driver seat control unit harness connector and ground.

(+) Driver seat control unit		(-)	Power source	Condition	Voltage (V) (Approx.)
Connector	Terminal				
B223	37	Ground	Battery power supply	Ignition switch OFF	Battery voltage

Is the inspection result normal?

YES >> GO TO 3.

NO >> Check the following:

- Repair or replace harness.
- Circuit breaker.

### 3. CHECK GROUND CIRCUIT

Check continuity between the driver seat control unit harness connector and ground.

Driver seat control unit		Ground	Continuity
Connector	Terminal		
B223	39		Yes

Is the inspection result normal?

YES >> Inspection End.

NO >> Repair or replace harness.

## DRIVER SEAT CONTROL UNIT : Special Repair Requirement

INFOID:000000012246498

### 1. PERFORM ADDITIONAL SERVICE

Perform additional service when removing battery negative terminal.

>> Refer to [ADP-53. "ADDITIONAL SERVICE WHEN REMOVING BATTERY NEGATIVE TERMINAL : Work Procedure"](#).

## AUTOMATIC DRIVE POSITIONER CONTROL UNIT

### AUTOMATIC DRIVE POSITIONER CONTROL UNIT : Diagnosis Procedure

INFOID:000000012246499

#### NOTE:

Do not disconnect the battery negative terminal and the driver seat control unit connector until DTC is confirmed with CONSULT.

Regarding Wiring Diagram information, refer to [ADP-38. "Wiring Diagram"](#).

# POWER SUPPLY AND GROUND CIRCUIT

< DTC/CIRCUIT DIAGNOSIS >

## 1. CHECK FUSE

Check that the following fusible link is not blown.

Signal name	Fusible link No.
Battery power supply	I (40 A)

Is the inspection result normal?

YES >> GO TO 2.

NO >> Replace the blown fusible after repairing the affected circuit.

## 2. CHECK POWER SUPPLY CIRCUIT

1. Turn ignition switch OFF.
2. Disconnect automatic drive positioner control unit.
3. Check voltage between automatic drive positioner control unit harness connector and ground.

(+)		(-)	Voltage (V) (Approx.)
Automatic drive positioner control unit			
Connector	Terminal		
M67	25	Ground	Battery voltage

Is the inspection result normal?

YES >> GO TO 3.

NO >> Check the following:

- Repair or replace harness.
- Circuit breaker.

## 3. CHECK GROUND CIRCUIT

Check continuity between the automatic drive positioner control unit harness connector and ground.

Automatic drive positioner control unit		Ground	Continuity
Connector	Terminal		
M67	30		Yes

Is the inspection result normal?

YES >> Inspection End.

NO >> Repair or replace harness.

## AUTOMATIC DRIVE POSITIONER CONTROL UNIT : Special Repair Requirement

INFOID:000000012246500

### 1. PERFORM ADDITIONAL SERVICE

Perform additional service when removing battery negative terminal.

>> Refer to [ADP-53. "ADDITIONAL SERVICE WHEN REMOVING BATTERY NEGATIVE TERMINAL : Work Procedure"](#).

# SLIDING SWITCH

< DTC/CIRCUIT DIAGNOSIS >

## SLIDING SWITCH

### Component Function Check

INFOID:000000012246501

#### 1. DATA MONITOR

##### CONSULT

1. Select "Data Monitor" mode of "AUTO DRIVE POS."
2. Select "SLIDE SW-FR", "SLIDE SW-RR".
3. Check that the function operates normally according to the following conditions:

Monitor item	Condition	Status	
SLIDE SW-FR	Sliding switch (forward)	Operate	ON
		Release	OFF
SLIDE SW-RR	Sliding switch (backward)	Operate	ON
		Release	OFF

Is the inspection result normal?

YES >> Inspection End.

NO >> Perform diagnosis procedure. Refer to [ADP-72. "Diagnosis Procedure"](#).

### Diagnosis Procedure

INFOID:000000012246502

Regarding Wiring Diagram information, refer to [ADP-38. "Wiring Diagram"](#).

#### 1. CHECK SLIDING SWITCH SIGNAL

1. Turn ignition switch OFF.
2. Check voltage between driver seat control unit harness connector and ground.

(+) Driver seat control unit		(-)	Condition	Voltage (V) (Approx.)	
Connector	Terminals				
B222	9	Ground	Sliding switch	Operate (backward)	0
				Release	Battery voltage
	25			Operate (forward)	0
				Release	Battery voltage

Is the inspection result normal?

YES >> GO TO 5.

NO >> GO TO 2.

#### 2. CHECK SLIDING SWITCH CIRCUIT

1. Turn ignition switch OFF.
2. Disconnect driver seat control unit and power seat switch LH.
3. Check continuity between driver seat control unit harness connector and power seat switch LH harness connector.

Driver seat control unit		Power seat switch LH		Continuity
Connector	Terminal	Connector	Terminal	
B222	9	B213	6	Yes
	25		7	

4. Check continuity between driver seat control unit harness connector and ground.



# SLIDING SWITCH

## < DTC/CIRCUIT DIAGNOSIS >

Driver seat control unit		Ground	Continuity
Connector	Terminal		
B222	9		No
	25		

Is the inspection result normal?

YES >> GO TO 3.

NO >> Repair or replace harness.

### 3. CHECK DRIVER SEAT CONTROL UNIT OUTPUT

1. Connect the driver seat control unit.
2. Turn ignition switch ON.
3. Check voltage between driver seat control unit harness connector and ground.

(+)		(-)	Voltage (V) (Approx.)
Driver seat control unit			
Connector	Terminal		
B222	9	Ground	Battery voltage
	25		

Is the inspection result normal?

YES >> GO TO 4.

NO >> Replace driver seat control unit. Refer to [ADP-130, "Removal and Installation"](#).

### 4. CHECK SLIDING SWITCH

Refer to [ADP-73, "Component Inspection"](#).

Is the inspection result normal?

YES >> GO TO 5.

NO >> Replace power seat switch LH. Refer to [ADP-133, "Removal and Installation"](#).

### 5. CHECK INTERMITTENT INCIDENT

Refer to [GI-41, "Intermittent Incident"](#).

Is the inspection result normal?

YES >> Replace driver seat control unit. Refer to [ADP-130, "Removal and Installation"](#).

NO >> Repair or replace malfunctioning part.

## Component Inspection

INFOID:0000000012246503

### 1. CHECK SLIDING SWITCH

1. Turn ignition switch OFF.
2. Disconnect power seat switch LH.
3. Check continuity between power seat switch LH terminals.

Power seat switch LH		Condition	Continuity	
Terminals				
3	6	Sliding switch (backward)	Operate	Yes
			Release	No
	7	Sliding switch (forward)	Operate	Yes
			Release	No

Is the inspection result normal?

YES >> Inspection End.

NO >> Replace power seat switch LH. Refer to [ADP-133, "Removal and Installation"](#).

# RECLINING SWITCH

< DTC/CIRCUIT DIAGNOSIS >

## RECLINING SWITCH

### Component Function Check

INFOID:000000012246504

#### 1. DATA MONITOR

##### CONSULT

1. Select "Data Monitor" mode of "AUTO DRIVE POS".
2. Select "RECLN SW-FR", "RECLN SW-RR".
3. Check that the function operates normally according to the following conditions:

Monitor item	Condition	Status	
RECLN SW-FR	Reclining switch (forward)	Operate	ON
		Release	OFF
RECLN SW-RR	Reclining switch (backward)	Operate	ON
		Release	OFF

Is the inspection result normal?

YES >> Inspection End.

NO >> Perform diagnosis procedure. Refer to [ADP-74, "Diagnosis Procedure"](#).

### Diagnosis Procedure

INFOID:000000012246505

Regarding Wiring Diagram information, refer to [ADP-38, "Wiring Diagram"](#).

#### 1. CHECK RECLINING SWITCH SIGNAL

1. Turn ignition switch OFF.
2. Check voltage between driver seat control unit harness connector and ground.

(+) Driver seat control unit		(-)	Condition	Voltage (V) (Approx.)
Connector	Terminal			
B222	24	Ground	Operate (forward)	0
			Release	Battery voltage
	8		Operate (backward)	0
			Release	Battery voltage

Is the inspection result normal?

YES >> GO TO 5.

NO >> GO TO 2.

#### 2. CHECK RECLINING SWITCH CIRCUIT

1. Turn ignition switch OFF.
2. Disconnect driver seat control unit and power seat switch LH.
3. Check continuity between driver seat control unit harness connector and power seat switch LH harness connector.

Driver seat control unit		Power seat switch LH		Continuity
Connector	Terminal	Connector	Terminal	
B222	24	B213	5	Yes
	8		10	

4. Check continuity between driver seat control unit harness connector and ground.

# RECLINING SWITCH

## < DTC/CIRCUIT DIAGNOSIS >

Driver seat control unit		Ground	Continuity
Connector	Terminal		
B222	24		No
	8		

Is the inspection result normal?

YES >> GO TO 3.

NO >> Repair or replace harness.

### 3. CHECK DRIVER SEAT CONTROL UNIT OUTPUT

1. Connect the driver seat control unit.
2. Turn ignition switch ON.
3. Check voltage between driver seat control unit harness connector and ground.

(+)		(-)	Voltage (V) (Approx.)
Driver seat control unit			
Connector	Terminal		
B222	8	Ground	Battery voltage
	24		

Is the inspection result normal?

YES >> GO TO 4.

NO >> Replace driver seat control unit. Refer to [ADP-130, "Removal and Installation"](#).

### 4. CHECK RECLINING SWITCH

Refer to [ADP-75, "Component Inspection"](#).

Is the inspection result normal?

YES >> GO TO 5.

NO >> Replace power seat switch LH. Refer to [ADP-133, "Removal and Installation"](#).

### 5. CHECK INTERMITTENT INCIDENT

Refer to [GI-41, "Intermittent Incident"](#).

Is the inspection result normal?

YES >> Replace driver seat control unit. Refer to [ADP-130, "Removal and Installation"](#).

NO >> Repair or replace the malfunctioning part.

## Component Inspection

INFOID:000000012246506

### 1. CHECK RECLINING SWITCH

1. Turn ignition switch OFF.
2. Disconnect power seat switch LH.
3. Check continuity between power seat switch LH terminals.

Power seat switch LH		Condition		Continuity
Terminals				
3	10	Reclining switch (backward)	Operate	Yes
			Release	No
	5	Reclining switch (forward)	Operate	Yes
			Release	No

Is the inspection result normal?

YES >> Inspection End.

NO >> Replace power seat switch LH. Refer to [ADP-133, "Removal and Installation"](#).

# LIFTING SWITCH (FRONT)

< DTC/CIRCUIT DIAGNOSIS >

## LIFTING SWITCH (FRONT)

### Component Function Check

INFOID:000000012246507

#### 1. DATA MONITOR

##### CONSULT

1. Select "Data Monitor" mode of "AUTO DRIVE POS."
2. Select "LIFT FR SW-UP", "LIFT FR SW-DN".
3. Check that the function operates normally according to the following conditions:

Monitor item	Condition	Status	
LIFT FR SW-UP	Lifting switch front (up)	Operate	ON
		Release	OFF
LIFT FR SW-DN	Lifting switch front (down)	Operate	ON
		Release	OFF

Is the inspection result normal?

YES >> Inspection End.

NO >> Perform diagnosis procedure. Refer to [ADP-76, "Diagnosis Procedure"](#).

### Diagnosis Procedure

INFOID:000000012246508

Regarding Wiring Diagram information, refer to [ADP-38, "Wiring Diagram"](#).

#### 1. CHECK LIFTING SWITCH SIGNAL

1. Turn ignition switch OFF.
2. Check voltage between driver seat control unit harness connector and ground.

(+) Driver seat control unit		(-)	Condition	Voltage (V) (Approx.)
Connector	Terminal			
B222	7	Ground	Operate (down)	0V
			Release	Battery voltage
	23		Operate (up)	0V
			Release	Battery voltage

Is the inspection result normal?

YES >> GO TO 5.

NO >> GO TO 2.

#### 2. CHECK LIFTING SWITCH (FRONT) CIRCUIT

1. Turn ignition switch OFF.
2. Disconnect driver seat control unit and power seat switch LH.
3. Check continuity between driver seat control unit harness connector and power seat switch LH harness connector.

Driver seat control unit		Power seat switch LH		Continuity
Connector	Terminal	Connector	Terminal	
B222	7	B213	1	Yes
	23		8	

4. Check continuity between driver seat control unit harness connector and ground.

# LIFTING SWITCH (FRONT)

## < DTC/CIRCUIT DIAGNOSIS >

Driver seat control unit		Ground	Continuity
Connector	Terminal		
B222	7		No
	23		

Is the inspection result normal?

YES >> GO TO 3.

NO >> Repair or replace harness.

### 3. CHECK DRIVER SEAT CONTROL UNIT OUTPUT

1. Connect the driver seat control unit.
2. Turn ignition switch ON.
3. Check voltage between driver seat control unit harness connector and ground.

(+)		(-)	Voltage (V) (Approx.)
Driver seat control unit			
Connector	Terminal	Ground	Battery voltage
B222	7		
	23		

Is the inspection result normal?

YES >> GO TO 4.

NO >> Replace driver seat control unit. Refer to [ADP-130, "Removal and Installation"](#).

### 4. CHECK LIFTING SWITCH (FRONT)

Refer to [ADP-77, "Component Inspection"](#).

Is the inspection result normal?

YES >> GO TO 5.

NO >> Replace power seat switch LH. Refer to [ADP-133, "Removal and Installation"](#).

### 5. CHECK INTERMITTENT INCIDENT

Refer to [GI-41, "Intermittent Incident"](#).

Is the inspection result normal?

YES >> Replace driver seat control unit. Refer to [ADP-130, "Removal and Installation"](#).

NO >> Repair or replace the malfunctioning part.

## Component Inspection

INFOID:0000000012246509

### 1. CHECK LIFTING SWITCH (FRONT)

1. Turn ignition switch OFF.
2. Disconnect power seat switch LH.
3. Check continuity between power seat switch LH terminals.

Power seat switch LH		Condition	Continuity	
Terminals				
3	1	Lifting switch front (down)	Operate	Yes
			Release	No
	8	Lifting switch front (up)	Operate	Yes
			Release	No

Is the inspection result normal?

YES >> Inspection End.

NO >> Replace power seat switch LH. Refer to [ADP-133, "Removal and Installation"](#).

# LIFTING SWITCH (REAR)

< DTC/CIRCUIT DIAGNOSIS >

## LIFTING SWITCH (REAR)

### Component Function Check

INFOID:000000012246510

#### 1. DATA MONITOR

##### CONSULT

1. Select "Data Monitor" mode of "AUTO DRIVE POS."
2. Select "LIFT RR SW-UP", "LIFT RR SW-DN".
3. Check that the function operates normally according to the following conditions:

Monitor item	Condition	Status	
LIFT RR SW-UP	Lifting switch rear (up)	Operate	ON
		Release	OFF
LIFT RR SW-DN	Lifting switch rear (down)	Operate	ON
		Release	OFF

Is the inspection result normal?

YES >> Inspection End.

NO >> Perform diagnosis procedure. Refer to [ADP-78, "Diagnosis Procedure"](#).

### Diagnosis Procedure

INFOID:000000012246511

Regarding Wiring Diagram information, refer to [ADP-38, "Wiring Diagram"](#).

#### 1. CHECK LIFTING SWITCH (REAR) SIGNAL

1. Turn ignition switch OFF.
2. Check voltage between driver seat control unit harness connector and ground.

(+)		(-)	Condition	Voltage (V) (Approx.)	
Connector	Terminal				
B222	6	Ground	Lifting switch (rear)	Operate (down)	0
			Release	Battery voltage	
	22		Operate (up)	0	
			Release	Battery voltage	

Is the inspection result normal?

YES >> GO TO 5.

NO >> GO TO 2.

#### 2. CHECK LIFTING SWITCH (REAR) CIRCUIT

1. Turn ignition switch OFF.
2. Disconnect driver seat control unit and power seat switch LH.
3. Check continuity between driver seat control unit harness connector and power seat switch LH harness connector.

Driver seat control unit		Power seat switch LH		Continuity
Connector	Terminal	Connector	Terminal	
B222	6	B213	2	Yes
	22		9	

4. Check continuity between driver seat control unit harness connector and ground.

## LIFTING SWITCH (REAR)

< DTC/CIRCUIT DIAGNOSIS >

Driver seat control unit		Ground	Continuity
Connector	Terminal		
B222	6		No
	22		

Is the inspection result normal?

YES >> GO TO 3.

NO >> Repair or replace harness.

### 3. CHECK DRIVER SEAT CONTROL UNIT OUTPUT

1. Connect the driver seat control unit.
2. Turn ignition switch ON.
3. Check voltage between driver seat control unit harness connector and ground.

(+)		(-)	Voltage (V) (Approx.)
Driver seat control unit			
Connector	Terminal		
B222	6	Ground	Battery voltage
	22		

Is the inspection result normal?

YES >> GO TO 4.

NO >> Replace driver seat control unit. Refer to [ADP-130, "Removal and Installation"](#).

### 4. CHECK LIFTING SWITCH (REAR)

Refer to [ADP-79, "Component Inspection"](#).

Is the inspection result normal?

YES >> GO TO 5.

NO >> Replace power seat switch LH. Refer to [ADP-133, "Removal and Installation"](#).

### 5. CHECK INTERMITTENT INCIDENT

Refer to [GI-41, "Intermittent Incident"](#).

Is the inspection result normal?

YES >> Replace driver seat control unit. Refer to [ADP-130, "Removal and Installation"](#).

NO >> Repair or replace the malfunctioning part.

## Component Inspection

INFOID:0000000012246512

### 1. CHECK LIFTING SWITCH (REAR)

1. Turn ignition switch OFF.
2. Disconnect power seat switch LH.
3. Check continuity between power seat switch LH terminals.

Power seat switch LH		Condition	Continuity	
Terminals				
3	9	Lifting switch rear (up)	Operate	Yes
			Release	No
	2	Lifting switch rear (down)	Operate	Yes
			Release	No

Is the inspection result normal?

YES >> Inspection End.

NO >> Replace power seat switch LH. Refer to [ADP-133, "Removal and Installation"](#).

# TILT SWITCH

< DTC/CIRCUIT DIAGNOSIS >

## TILT SWITCH

### Component Function Check

INFOID:000000012246513

#### 1. DATA MONITOR

##### CONSULT

1. Select "Data Monitor" mode of "AUTO DRIVE POS."
2. Select "TILT SW-UP", "TILT SW-DOWN".
3. Check that the function operates normally according to the following conditions:

Monitor item	Condition		Status
TILT SW-UP	Tilt switch (up)	Operate	ON
		Release	OFF
TILT SW-DOWN	Tilt switch (down)	Operate	ON
		Release	OFF

Is the inspection result normal?

YES >> Inspection End.

NO >> Perform diagnosis procedure. Refer to [ADP-80, "Diagnosis Procedure"](#).

### Diagnosis Procedure

INFOID:000000012246514

Regarding Wiring Diagram information, refer to [ADP-38, "Wiring Diagram"](#).

#### 1. CHECK TILT SWITCH SIGNAL

1. Disconnect ADP steering switch (tilt switch).
2. Check voltage between ADP steering switch harness connector and ground.

(+)		(-)	Voltage (V) (Approx.)
ADP steering switch (tilt switch)			
Connector	Terminal	Ground	Battery voltage
M39	4		
	5		

Is the inspection result normal?

YES >> GO TO 3.

NO >> GO TO 2.

#### 2. CHECK TILT SWITCH CIRCUIT

1. Disconnect automatic drive positioner control unit.
2. Check continuity between automatic drive positioner control unit harness connector and ADP steering switch harness connector.

Automatic drive positioner control unit		ADP steering switch (tilt switch)		Continuity
Connector	Terminal	Connector	Terminal	
M63	1	M39	4	Yes
	13		5	

3. Check continuity between automatic drive positioner control unit harness connector and ground.



# TILT SWITCH

## < DTC/CIRCUIT DIAGNOSIS >

Automatic drive positioner control unit		Ground	Continuity
Connector	Terminal		
M63	1		No
	13		

Is the inspection result normal?

- YES >> Replace automatic drive positioner unit. Refer to [ADP-131, "Removal and Installation"](#).  
 NO >> Repair or replace harness.

### 3. CHECK TILT SWITCH

Refer to [ADP-81, "Component Inspection"](#).

Is the inspection result normal?

- YES >> GO TO 4.  
 NO >> Replace ADP steering switch (tilt switch). Refer to [ADP-134, "Removal and Installation"](#).

### 4. CHECK INTERMITTENT INCIDENT

Refer to [GI-41, "Intermittent Incident"](#).

>> Inspection End.

## Component Inspection

INFOID:000000012246515

### 1. CHECK TILT SWITCH

- Turn ignition switch OFF.
- Disconnect ADP steering switch (tilt switch).
- Check continuity between ADP steering switch terminals.

ADP steering switch (tilt switch)		Condition	Continuity
Terminals			
1	4	Tilt switch (up)	Operate Yes
			Release No
	5	Tilt switch (down)	Operate Yes
			Release No

Is the inspection result normal?

- YES >> Inspection End.  
 NO >> Replace ADP steering switch (tilt switch). Refer to [ADP-134, "Removal and Installation"](#).

# TELESCOPIC SWITCH

< DTC/CIRCUIT DIAGNOSIS >

## TELESCOPIC SWITCH

### Component Function Check

INFOID:000000012246516

#### 1. DATA MONITOR

##### CONSULT

1. Select "Data Monitor" mode of "AUTO DRIVE POS".
2. Select "TELESCO SW-FR", "TELESCO SW-RR".
3. Check that the function operates normally according to the following conditions:

Monitor item	Condition		Status
TELESCO SW-FR	Telescopic switch (forward)	Operate	ON
		Release	OFF
TELESCO SW-RR	Telescopic switch (backward)	Operate	ON
		Release	OFF

Is the inspection result normal?

YES >> Inspection End.

NO >> Perform diagnosis procedure. Refer to [ADP-82. "Diagnosis Procedure"](#).

### Diagnosis Procedure

INFOID:000000012246517

Regarding Wiring Diagram information, refer to [ADP-38. "Wiring Diagram"](#).

#### 1. CHECK TELESCOPIC SWITCH SIGNAL

1. Disconnect ADP steering switch (telescopic switch).
2. Check voltage between ADP steering switch harness connector and ground.

(+)		(-)	Voltage (V) (Approx.)
ADP steering switch (telescopic switch)			
Connector	Terminal	Ground	Battery voltage
M39	2		
	3		

Is the inspection result normal?

YES >> GO TO 3.

NO >> GO TO 2.

#### 2. CHECK TELESCOPIC SWITCH CIRCUIT

1. Disconnect automatic drive positioner control unit.
2. Check continuity between automatic drive positioner control unit harness connector and ADP steering switch harness connector.

Automatic drive positioner control unit		ADP steering switch (telescopic switch)		Continuity
Connector	Terminal	Connector	Terminal	
M63	7	M39	2	Yes
	19		3	

3. Check continuity between automatic drive positioner control unit harness connector and ground.

# TELESCOPIC SWITCH

## < DTC/CIRCUIT DIAGNOSIS >

Automatic drive positioner control unit		Ground	Continuity
Connector	Terminal		
M63	7		No
	19		

Is the inspection result normal?

YES >> Replace automatic drive positioner unit. Refer to [ADP-131, "Removal and Installation"](#).

NO >> Repair or replace harness.

### 3. CHECK TELESCOPIC SWITCH

Refer to [ADP-83, "Component Inspection"](#).

Is the inspection result normal?

YES >> GO TO 4.

NO >> Replace ADP steering switch (telescopic switch). Refer to [ADP-134, "Removal and Installation"](#).

### 4. CHECK INTERMITTENT INCIDENT

Refer to [GI-41, "Intermittent Incident"](#).

>> Inspection End.

## Component Inspection

INFOID:000000012246518

### 1. CHECK TELESCOPIC SWITCH

1. Turn ignition switch OFF.
2. Disconnect ADP steering switch (telescopic switch).
3. Check continuity between ADP steering switch terminals.

ADP steering switch (telescopic switch)		Condition	Continuity	
Terminals				
1	2	Telescopic switch (forward)	Operate	Yes
			Release	No
	3	Telescopic switch (backward)	Operate	Yes
			Release	No

Is the inspection result normal?

YES >> Inspection End.

NO >> Replace ADP steering switch (telescopic switch). Refer to [ADP-134, "Removal and Installation"](#).

# SEAT MEMORY SWITCH

< DTC/CIRCUIT DIAGNOSIS >

## SEAT MEMORY SWITCH

### Component Function Check

INFOID:000000012246519

#### 1. DATA MONITOR

##### CONSULT

1. Select "Data Monitor" mode of "AUTO DRIVE POS".
2. Select "MEMORY SW 1", "MEMORY SW 2", "SET SW".
3. Check that the function operates normally according to the following conditions:

Monitor item	Condition	Status	
MEMORY SW 1	Memory switch 1	Push	ON
		Release	OFF
MEMORY SW 2	Memory switch 2	Push	ON
		Release	OFF
SET SW	Set switch	Push	ON
		Release	OFF

Is the inspection result normal?

YES >> Inspection End.

NO >> Perform diagnosis procedure. Refer to [ADP-84. "Diagnosis Procedure"](#).

#### Diagnosis Procedure

INFOID:000000012246520

Regarding Wiring Diagram information, refer to [ADP-38. "Wiring Diagram"](#).

#### 1. CHECK SEAT MEMORY SWITCH SIGNAL

1. Turn ignition switch OFF.
2. Disconnect seat memory switch.
3. Turn ignition switch ON.
4. Check voltage between seat memory switch harness connector and ground.

(+)		(-)	Voltage (V) (Approx.)
Seat memory switch			
Connector	Terminal	Ground	5
D13	9		
	15		
	7		

Is the inspection result normal?

YES >> GO TO 3.

NO >> GO TO 2.

#### 2. CHECK MEMORY SWITCH CIRCUIT

1. Turn ignition switch OFF.
2. Disconnect driver seat control unit.
3. Check continuity between driver seat control unit harness connector and seat memory switch harness connector.

# SEAT MEMORY SWITCH

## < DTC/CIRCUIT DIAGNOSIS >

Driver seat control unit		Seat memory switch		Continuity
Connector	Terminal	Connector	Terminal	
B222	11	D13	9	Yes
	21		7	
	27		15	

4. Check continuity between driver seat control unit harness connector and ground.

Driver seat control unit		Ground	Continuity
Connector	Terminal		
B222	11	Ground	No
	21		
	27		

Is the inspection result normal?

YES >> Replace driver seat control unit. Refer to [ADP-130, "Removal and Installation"](#).

NO >> Repair or replace harness.

### 3. CHECK MEMORY SWITCH GROUND CIRCUIT

Check continuity between seat memory switch harness connector and ground.

Seat memory switch		Ground	Continuity
Connector	Terminal		
D13	16	Ground	Yes

Is the inspection result normal?

YES >> GO TO 4.

NO >> Repair or replace harness.

### 4. CHECK SEAT MEMORY SWITCH

Refer to [ADP-85, "Component Inspection"](#).

Is the inspection result normal?

YES >> Check intermittent incident. Refer to [GI-41, "Intermittent Incident"](#).

NO >> Replace seat memory switch. Refer to [ADP-132, "Removal and Installation"](#).

## Component Inspection

INFOID:0000000012246521

### 1. CHECK SEAT MEMORY SWITCH

1. Turn ignition switch OFF.
2. Disconnect seat memory switch.
3. Check continuity between seat memory switch terminals.

Seat memory switch		Condition	Continuity	
Terminals				
16	15	Memory switch 1	Push	Yes
			Release	No
	9	Memory switch 2	Push	Yes
			Release	No
	7	Set switch	Push	Yes
			Release	No

Is the inspection result normal?

YES >> Inspection End.

## SEAT MEMORY SWITCH

< DTC/CIRCUIT DIAGNOSIS >

---

NO >> Replace seat memory switch. Refer to [ADP-132. "Removal and Installation"](#).

# DOOR MIRROR REMOTE CONTROL SWITCH

< DTC/CIRCUIT DIAGNOSIS >

## DOOR MIRROR REMOTE CONTROL SWITCH SELECT SWITCH

### SELECT SWITCH : Component Function Check

INFOID:000000012246522

#### 1. DATA MONITOR

##### CONSULT

1. Select "Data Monitor" mode of "AUTO DRIVE POS."
2. Select "MIR CHNG SW-R", "MIR CHNG SW-L".
3. Check that the function operates normally according to the following conditions:

Monitor item	Condition		Status
MIR CHNG SW-R	Mirror switch (right)	Operate	ON
		Release	OFF
MIR CHNG SW-L	Mirror switch (left)	Operate	ON
		Release	OFF

Is the inspection result normal?

YES >> Inspection End.

NO >> Perform diagnosis procedure. Refer to [ADP-87. "SELECT SWITCH : Diagnosis Procedure"](#).

### SELECT SWITCH : Diagnosis Procedure

INFOID:000000012246523

Regarding Wiring Diagram information, refer to [ADP-38. "Wiring Diagram"](#).

#### 1. CHECK SELECT SWITCH SIGNAL

1. Turn ignition switch ON.
2. Check voltage between automatic drive positioner control unit connector and ground.

(+)		(-)	Select switch condition	Voltage (V) (Approx.)
Connector	Terminal			
M63	2	Ground	RIGHT	0
			Other than above	5
	14		LEFT	0
			Other than above	5

Is the inspection result normal?

YES >> GO TO 5.

NO >> GO TO 2.

#### 2. CHECK HARNESS CONTINUITY

1. Turn ignition switch OFF.
2. Disconnect automatic drive positioner control unit and door mirror remote control switch.
3. Check continuity between automatic drive positioner control unit connector and door mirror remote control switch connector.

Automatic drive positioner control unit		Door mirror remote control switch		Continuity
Connector	Terminal	Connector	Terminal	
M63	2	D19	4	Yes
	14		3	

## DOOR MIRROR REMOTE CONTROL SWITCH

### < DTC/CIRCUIT DIAGNOSIS >

4. Check continuity between automatic drive positioner control unit connector and ground.

Automatic drive positioner control unit		Ground	Continuity
Connector	Terminal		
M63	2		No
	14		

Is the inspection result normal?

YES >> GO TO 3.

NO >> Repair or replace harness.

### 3. CHECK DOOR MIRROR REMOTE CONTROL SWITCH GROUND CIRCUIT

Check continuity between door mirror remote control switch connector and ground.

Door mirror remote control switch		Ground	Continuity
Connector	Terminal		
D19	15		Yes

Is the inspection result normal?

YES >> GO TO 4.

NO >> Repair or replace harness.

### 4. CHECK SELECT SWITCH

Check select switch.

Refer to [ADP-88, "SELECT SWITCH : Component Inspection"](#).

Is the inspection result normal?

YES >> Refer to [GI-41, "Intermittent Incident"](#).

NO >> Replace door mirror remote control switch. Refer to [MIR-26, "Removal and Installation"](#).

### 5. CHECK INTERMITTENT INCIDENT

Check intermittent incident.

Refer to [GI-41, "Intermittent Incident"](#).

Is the inspection result normal?

YES >> Replace automatic drive positioner control unit. Refer to [ADP-131, "Removal and Installation"](#).

NO >> Repair or replace the malfunctioning parts.

### SELECT SWITCH : Component Inspection

INFOID:000000012246524

### 1. CHECK SELECT SWITCH

Check door mirror remote control switch.

Door mirror remote control switch		Select switch condition	Continuity
Terminals			
3	15	LEFT	Yes
		Other than above	No
4		RIGHT	Yes
		Other than above	No

Is the inspection result normal?

YES >> Inspection End.

NO >> Replace door mirror remote control switch. Refer to [MIR-26, "Removal and Installation"](#).

### MIRROR SWITCH



# DOOR MIRROR REMOTE CONTROL SWITCH

< DTC/CIRCUIT DIAGNOSIS >

## MIRROR SWITCH : Component Function Check

INFOID:000000012246525

### 1. DATA MONITOR

#### CONSULT

1. Select "Data Monitor" mode of "AUTO DRIVE POS."
2. Select "MIR CON SW-UP/DN", "MIR CON SW-RH/LH".
3. Check that the function operates normally according to the following conditions:

Monitor item	Condition		Status
MIR CON SW-UP/DN	Mirror switch (up/down)	Operate	ON
		Release	OFF
MIR CON SW-RH/LH	Mirror switch (right/left)	Operate	ON
		Release	OFF

Is the inspection result normal?

YES >> Inspection End.

NO >> Perform diagnosis procedure. Refer to [ADP-89, "MIRROR SWITCH : Diagnosis Procedure"](#).

### MIRROR SWITCH : Diagnosis Procedure

INFOID:000000012246526

Regarding Wiring Diagram information, refer to [ADP-38, "Wiring Diagram"](#).

### 1. CHECK MIRROR SWITCH FUNCTION

1. Turn ignition switch ON.
2. Check voltage between automatic drive positioner control unit connector and ground.

(+) Automatic drive positioner control unit		(-)	Mirror switch condition	Voltage (V) (Approx.)
Connector	Terminal			
M63	3	Ground	UP	0
			Other than above	5
	4		LEFT	0
			Other than above	5
	15		DOWN	0
			Other than above	5
	16		RIGHT	0
			Other than above	5

Is the inspection result normal?

YES >> GO TO 5.

NO >> GO TO 2.

### 2. CHECK HARNESS CONTINUITY

1. Turn ignition switch OFF.
2. Disconnect automatic drive positioner control unit and door mirror remote control switch.
3. Check continuity between automatic drive positioner control unit connector and door mirror remote control switch connector.

# DOOR MIRROR REMOTE CONTROL SWITCH

## < DTC/CIRCUIT DIAGNOSIS >

Automatic drive positioner control unit		Door mirror remote control switch		Continuity
Connector	Terminal	Connector	Terminal	
M63	3	D19	16	Yes
	4		9	
	15		12	
	16		1	

4. Check continuity between automatic drive positioner control unit connector and ground.

Automatic drive positioner control unit		Ground	Continuity
Connector	Terminal		
M63	3	Ground	No
	4		
	15		
	16		

Is the inspection result normal?

YES >> GO TO 3.

NO >> Repair or replace harness.

### 3. CHECK DOOR MIRROR REMOTE CONTROL SWITCH GROUND CIRCUIT

Check continuity between door mirror remote control switch connector and ground.

Door mirror remote control switch		Ground	Continuity
Connector	Terminal		
D19	15		Yes

Is the inspection result normal?

YES >> GO TO 4.

NO >> Repair or replace harness.

### 4. CHECK MIRROR SWITCH

Check mirror switch.

Refer to [ADP-90, "MIRROR SWITCH : Component Inspection"](#).

Is the inspection result normal?

YES >> Refer to [GI-41, "Intermittent Incident"](#).

NO >> Replace door mirror remote control switch. Refer to [MIR-26, "Removal and Installation"](#).

### 5. CHECK INTERMITTENT INCIDENT

Check intermittent incident.

Refer to [GI-41, "Intermittent Incident"](#).

Is the inspection result normal?

YES >> Replace automatic drive positioner control unit. Refer to [ADP-131, "Removal and Installation"](#).

NO >> Repair or replace the malfunctioning parts.

## MIRROR SWITCH : Component Inspection

INFOID:0000000012246527

### 1. CHECK MIRROR SWITCH

Check door mirror remote control switch.

Door mirror remote control switch	Mirror switch condition	Continuity
Terminals		

## DOOR MIRROR REMOTE CONTROL SWITCH

### < DTC/CIRCUIT DIAGNOSIS >

1	15	RIGHT	Yes
		Other than above	No
9		LEFT	Yes
		Other than above	No
16		UP	Yes
		Other than above	No
12		DOWN	Yes
		Other than above	No

**Is the inspection result normal?**

YES >> Inspection End.

NO >> Replace door mirror remote control switch. Refer to [MIR-26, "Removal and Installation"](#).

A  
B  
C  
D  
E  
F  
G  
H  
I  
K  
L  
M  
N  
O  
P

ADP

# POWER SEAT SWITCH GROUND CIRCUIT

< DTC/CIRCUIT DIAGNOSIS >

## POWER SEAT SWITCH GROUND CIRCUIT

### Diagnosis Procedure

INFOID:000000012246528

Regarding Wiring Diagram information, refer to [ADP-38, "Wiring Diagram"](#).

### 1. CHECK POWER SEAT SWITCH LH GROUND CIRCUIT

1. Turn ignition switch OFF.
2. Disconnect power seat switch LH.
3. Check continuity between power seat switch LH connector and ground.

Power seat switch LH		Ground	Continuity
Connector	Terminal		
B213	3		Yes

Is the inspection result normal?

- YES >> Check intermittent incident. Refer to [GI-41, "Intermittent Incident"](#).  
NO >> Repair or replace harness.

# TILT & TELESCOPIC SWITCH GROUND CIRCUIT

< DTC/CIRCUIT DIAGNOSIS >

## TILT & TELESCOPIC SWITCH GROUND CIRCUIT

### Diagnosis Procedure

INFOID:000000012246529

Regarding Wiring Diagram information, refer to [ADP-38, "Wiring Diagram"](#).

### 1. CHECK ADP STEERING SWITCH (TILT & TELESCOPIC SWITCH) GROUND CIRCUIT

1. Turn ignition switch OFF.
2. Disconnect ADP steering switch (tilt & telescopic switch).
3. Check continuity between ADP steering switch (tilt & telescopic switch) and ground.

ADP steering switch (tilt & telescopic switch)		Ground	Continuity
Connector	Terminal		
M39	1		Yes

Is the inspection result normal?

- YES >> Check intermittent incident. Refer to [GI-41, "Intermittent Incident"](#).  
NO >> Repair or replace harness.

A  
B  
C  
D  
E  
F  
G  
H  
I  
K  
L  
M  
N  
O  
P

ADP

# SLIDING SENSOR

< DTC/CIRCUIT DIAGNOSIS >

## SLIDING SENSOR

### Component Function Check

INFOID:0000000012246530

#### 1. DATA MONITOR

##### CONSULT

1. Select "Data Monitor" mode of "AUTO DRIVE POS."
2. Select "SLIDE PULSE".
3. Check that the function operates normally according to the following conditions:

Monitor item	Condition		Value
SLIDE PULSE	Seat sliding	Operate (forward)	Change (decrease)
		Operate (backward)	Change (increase)
		Release	No change

Is the inspection result normal?

YES >> Inspection End.

NO >> Perform diagnosis procedure. Refer to [ADP-94, "Diagnosis Procedure"](#).

### Diagnosis Procedure

INFOID:0000000012246531

Regarding Wiring Diagram information, refer to [ADP-38, "Wiring Diagram"](#).

#### 1. CHECK SLIDING SENSOR SIGNAL

1. Turn ignition switch ON.
2. Read voltage signal between driver seat control unit harness connector and ground with oscilloscope.

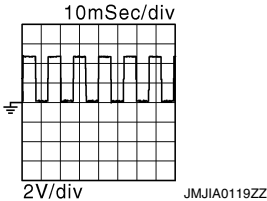
(+)		(-)	Condition	Voltage signal
Driver's seat control unit				
Connector	Terminal			
B222	31	Ground	Seat sliding	
			Other than above	

Is the inspection result normal?

YES >> Replace driver seat control unit. Refer to [ADP-130, "Removal and Installation"](#).

NO >> GO TO 2.

#### 2. CHECK SLIDING SENSOR CIRCUIT

1. Turn ignition switch OFF.
2. Disconnect driver seat control unit and sliding motor LH.
3. Check continuity between driver seat control unit harness connector and sliding motor LH harness connector.

Driver seat control unit		Sliding motor LH		Continuity
Connector	Terminal	Connector	Terminal	
B222	31	B226	3	Yes

# SLIDING SENSOR

## < DTC/CIRCUIT DIAGNOSIS >

4. Check continuity between driver seat control unit harness connector and ground.

Driver seat control unit		Ground	Continuity
Connector	Terminal		
B222	31		No

Is the inspection result normal?

- YES >> GO TO 3.  
 NO >> Repair or replace harness.

### 3. CHECK SLIDING SENSOR POWER SUPPLY

1. Connect driver seat control unit.
2. Turn ignition switch ON.
3. Check voltage between sliding motor LH harness connector and ground.

Sliding motor LH		Ground	Voltage (V) (Approx.)
Connector	Terminal		
B226	1		Battery voltage

Is the inspection result normal?

- YES >> GO TO 5.  
 NO >> GO TO 4.

### 4. CHECK SLIDING SENSOR POWER SUPPLY CIRCUIT

1. Turn ignition switch OFF.
2. Disconnect driver seat control unit.
3. Check continuity between driver seat control unit harness connector and sliding motor LH harness connector.

Driver seat control unit		Sliding motor LH		Continuity
Connector	Terminal	Connector	Terminal	
B222	5	B226	1	Yes

4. Check continuity between driver seat control unit harness connector and ground.

Driver seat control unit		Ground	Continuity
Connector	Terminal		
B222	5		No

Is the inspection result normal?

- YES >> Replace driver seat control unit. Refer to [ADP-130, "Removal and Installation"](#).  
 NO >> Repair or replace harness.

### 5. CHECK SLIDING SENSOR GROUND

1. Turn ignition switch OFF.
2. Check continuity between sliding motor LH harness connector and ground.

Sliding motor LH		Ground	Continuity
Connector	Terminal		
B226	2		Yes

Is the inspection result normal?

- YES >> Replace sliding motor LH. Refer to [SE-79, "Removal and Installation"](#).  
 NO >> Repair or replace harness.

A  
B  
C  
D  
E  
F  
G  
H  
I  
K  
L  
M  
N  
O  
P

ADP

# RECLINING SENSOR

< DTC/CIRCUIT DIAGNOSIS >

## RECLINING SENSOR

### Component Function Check

INFOID:000000012246532

#### 1. DATA MONITOR

##### CONSULT

1. Select "Data Monitor" mode of "AUTO DRIVE POS."
2. Select "RECLN PULSE".
3. Check that the function operates normally according to the following conditions:

Monitor item	Condition		Value
RECLN PULSE	Seat reclining	Operate (forward)	Change (decrease)
		Operate (backward)	Change (increase)
		Release	No change

Is the inspection result normal?

YES >> Inspection End.

NO >> Perform diagnosis procedure. Refer to [ADP-96, "Diagnosis Procedure"](#).

### Diagnosis Procedure

INFOID:000000012246533

Regarding Wiring Diagram information, refer to [ADP-38, "Wiring Diagram"](#).

#### 1. CHECK RECLINING SENSOR SIGNAL

1. Turn ignition switch ON.
2. Read voltage signal between driver seat control unit harness connector and ground with oscilloscope.

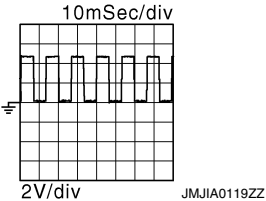
(+)		(-)	Condition	Voltage signal
Driver seat control unit Connector	Terminal			
B222	13	Ground	Seat reclining Operate	
			Other than above	0 or 5V

Is the inspection result normal?

YES >> Replace driver seat control unit. Refer to [ADP-130, "Removal and Installation"](#).

NO >> GO TO 2.

#### 2. CHECK RECLINING SENSOR CIRCUIT

1. Turn ignition switch OFF.
2. Disconnect driver seat control unit and reclining motor LH.
3. Check continuity between driver seat control unit harness connector and reclining motor LH harness connector.

Driver seat control unit		Reclining motor LH		Continuity
Connector	Terminal	Connector	Terminal	
B222	13	B225	1	Yes



# RECLINING SENSOR

## < DTC/CIRCUIT DIAGNOSIS >

4. Check continuity between driver seat control unit harness connector and ground.

Driver seat control unit		Ground	Continuity
Connector	Terminal		
B222	13		No

Is the inspection result normal?

- YES >> GO TO 3.  
NO >> Repair or replace harness.

### 3. CHECK RECLINING SENSOR POWER SUPPLY

1. Connect driver seat control unit.
2. Turn ignition switch ON.
3. Check voltage between reclining motor LH harness connector and ground.

Reclining motor LH		(-)	Voltage (V) (Approx.)
Connector	Terminal		
B225	3	Ground	Battery voltage

Is the inspection result normal?

- YES >> GO TO 5.  
NO >> GO TO 4.

### 4. CHECK RECLINING SENSOR POWER SUPPLY CIRCUIT

1. Turn ignition switch OFF.
2. Disconnect driver seat control unit.
3. Check continuity between driver seat control unit harness connector and reclining motor LH harness connector.

Driver seat control unit		Reclining motor LH		Continuity
Connector	Terminal	Connector	Terminal	
B222	5	B225	3	Yes

4. Check continuity between driver seat control unit harness connector and ground.

Driver seat control unit		Ground	Continuity
Connector	Terminal		
B222	5		No

Is the inspection result normal?

- YES >> Replace driver seat control unit. Refer to [ADP-130, "Removal and Installation"](#).  
NO >> Repair or replace harness.

### 5. CHECK RECLINING SENSOR GROUND

1. Turn ignition switch OFF.
2. Check continuity between reclining motor LH harness connector and ground.

Reclining motor LH		Ground	Continuity
Connector	Terminal		
B225	2		Yes

Is the inspection result normal?

- YES >> Replace reclining motor LH. Refer to [SE-79, "Removal and Installation"](#).  
NO >> Repair or replace harness.

# LIFTING SENSOR (FRONT)

< DTC/CIRCUIT DIAGNOSIS >

## LIFTING SENSOR (FRONT)

### Component Function Check

INFOID:000000012246534

#### 1. DATA MONITOR

##### CONSULT

1. Select "Data Monitor" mode of "AUTO DRIVE POS."
2. Select "LIFT FR PULSE".
3. Check that the function operates normally according to the following conditions:

Monitor item	Condition		Value
LIFT FR PULSE	Seat lifting (front)	Operate (up)	Change (decrease)
		Operate (down)	Change (increase)
		Release	No change

Is the inspection result normal?

YES >> Inspection End.

NO >> Perform diagnosis procedure. Refer to [ADP-98, "Diagnosis Procedure"](#).

### Diagnosis Procedure

INFOID:000000012246535

Regarding Wiring Diagram information, refer to [ADP-38, "Wiring Diagram"](#).

#### 1. CHECK LIFTING SENSOR (FRONT) SIGNAL

1. Turn ignition switch ON.
2. Read the voltage signal between driver seat control unit harness connector and ground with an oscilloscope.

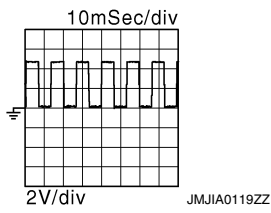
(+)		(-)	Condition		Voltage signal
Driver seat control unit	Connector				
	Terminal				
B222	30	Ground	Seat lifting (front)	Operate	
				Other than above	0 or 5V

Is the inspection result normal?

YES >> GO TO 4.

NO >> GO TO 2.

#### 2. CHECK LIFTING SENSOR (FRONT) CIRCUIT

1. Turn ignition switch OFF.
2. Disconnect driver seat control unit and lifting motor LH (front).
3. Check continuity between driver seat control unit harness connector and lifting motor LH (front) harness connector.

# LIFTING SENSOR (FRONT)

## < DTC/CIRCUIT DIAGNOSIS >

Driver seat control unit		Lifting motor LH (front)		Continuity
Connector	Terminal	Connector	Terminal	
B222	30	B227	1	Yes

4. Check continuity between driver seat control unit harness connector and ground.

Driver seat control unit		Ground	Continuity
Connector	Terminal		
B222	30		No

Is the inspection result normal?

YES >> GO TO 3.

NO >> Repair or replace harness.

### 3. CHECK LIFTING SENSOR (FRONT) POWER SUPPLY

1. Connect driver seat control unit.
2. Turn ignition switch ON.
3. Check voltage between lifting motor LH (front) harness connector and ground.

(+)		(-)	Voltage (V) (Approx.)
Lifting motor LH (front)			
Connector	Terminal		
B227	3	Ground	Battery voltage

Is the inspection result normal?

YES >> GO TO 5.

NO >> GO TO 4.

### 4. CHECK LIFTING SENSOR (FRONT) POWER SUPPLY CIRCUIT

1. Turn ignition switch OFF.
2. Disconnect driver seat control unit.
3. Check continuity between driver seat control unit harness connector and lifting motor LH (front) harness connector.

Driver seat control unit		Lifting motor LH (front)		Continuity
Connector	Terminal	Connector	Terminal	
B222	5	B227	3	Yes

4. Check continuity between driver seat control unit harness connector and ground.

Driver seat control unit		Ground	Continuity
Connector	Terminal		
B222	5		No

Is the inspection result normal?

YES >> Replace driver seat control unit. Refer to [ADP-130. "Removal and Installation"](#).

NO >> Repair or replace harness.

### 5. CHECK LIFTING SENSOR (FRONT) GROUND

1. Turn ignition switch OFF.
2. Check continuity between lifting motor LH (front) harness connector and ground.

Lifting motor LH (front)		Ground	Continuity
Connector	Terminal		
B227	2		Yes

A  
B  
C  
D  
E  
F  
G  
H  
I  
K  
L  
M  
N  
O  
P

ADP

## LIFTING SENSOR (FRONT)

< DTC/CIRCUIT DIAGNOSIS >

---

Is the inspection result normal?

- YES >> Replace lifting motor LH (front). Refer to [SE-79, "Removal and Installation"](#).
- NO >> Repair or replace harness.

# LIFTING SENSOR (REAR)

< DTC/CIRCUIT DIAGNOSIS >

## LIFTING SENSOR (REAR)

### Component Function Check

INFOID:000000012246536

#### 1. DATA MONITOR

##### CONSULT

1. Select "Data Monitor" mode of "AUTO DRIVE POS."
2. Select "LIFT RR PULSE".
3. Check lifting sensor (rear) signal under the following conditions:

Monitor item	Condition	Value	
LIFT RR PULSE	Seat lifting (rear)	Operate (up)	Change (decrease)
		Operate (down)	Change (increase)
	Release	No change	

Is the inspection result normal?

- YES >> Inspection End.  
 NO >> Perform diagnosis procedure. Refer to [ADP-101, "Diagnosis Procedure"](#).

### Diagnosis Procedure

INFOID:000000012246537

Regarding Wiring Diagram information, refer to [ADP-38, "Wiring Diagram"](#).

#### 1. CHECK LIFTING SENSOR (REAR) SIGNAL

1. Turn ignition switch ON.
2. Read voltage signal between driver seat control unit harness connector and ground with oscilloscope.

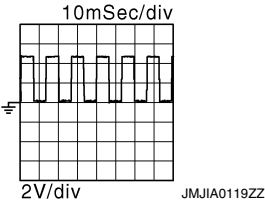
(+)		(-)	Condition	Voltage signal
Driver seat control unit Connector	Terminal			
B222	29	Ground	Seat lifting (rear) Operate	
			Other than above	0 or 5V

Is the inspection result normal?

- YES >> Replace driver seat control unit. Refer to [ADP-130, "Removal and Installation"](#).  
 NO >> GO TO 2.

#### 2. CHECK LIFTING SENSOR (REAR) CIRCUIT

1. Turn ignition switch OFF.
2. Disconnect driver seat control unit and lifting motor LH (rear).
3. Check the continuity between driver seat control unit harness connector and lifting motor LH (rear) harness connector.

Driver seat control unit		Lifting motor LH (rear)		Continuity
Connector	Terminal	Connector	Terminal	
B222	29	B228	3	Yes

## LIFTING SENSOR (REAR)

### < DTC/CIRCUIT DIAGNOSIS >

4. Check the continuity between driver seat control unit harness connector and ground.

Driver seat control unit		Ground	Continuity
Connector	Terminal		
B222	29		No

**Is the inspection result normal?**

- YES >> GO TO 3.  
 NO >> Repair or replace harness.

### 3. CHECK LIFTING SENSOR (REAR) POWER SUPPLY

1. Connect driver seat control unit.
2. Turn ignition switch ON.
3. Check the voltage between lifting motor LH (rear) harness connector and ground.

Lifting motor LH (rear)		(-)	Voltage (V) (Approx.)
Connector	Terminal		
B228	1	Ground	Battery voltage

**Is the inspection result normal?**

- YES >> GO TO 5.  
 NO >> GO TO 4.

### 4. CHECK LIFTING SENSOR (REAR) POWER SUPPLY CIRCUIT

1. Turn ignition switch OFF.
2. Disconnect driver seat control unit.
3. Check the continuity between driver seat control unit harness connector and lifting motor LH (rear) harness connector.

Driver seat control unit		Lifting motor LH (rear)		Continuity
Connector	Terminal	Connector	Terminal	
B222	5	B228	1	Yes

4. Check the continuity between driver seat control unit harness connector and ground.

Driver seat control unit		Ground	Continuity
Connector	Terminal		
B222	5		No

**Is the inspection result normal?**

- YES >> Replace driver seat control unit. Refer to [ADP-130, "Removal and Installation"](#).  
 NO >> Repair or replace harness.

### 5. CHECK LIFTING SENSOR (REAR) GROUND

1. Turn ignition switch OFF.
2. Check the continuity between lifting motor LH (rear) harness connector and ground.

Lifting motor LH (rear)		Ground	Continuity
Connector	Terminal		
B228	2		Yes

**Is the inspection result normal?**

- YES >> Replace lifting motor LH (rear). Refer to [SE-79, "Removal and Installation"](#).  
 NO >> Repair or replace harness.

# TILT SENSOR

< DTC/CIRCUIT DIAGNOSIS >

## TILT SENSOR

### Component Function Check

INFOID:000000012246538

#### 1. DATA MONITOR

##### CONSULT

1. Select "Data Monitor" mode of "AUTO DRIVE POS."
2. Select "TILT PULSE".
3. Check that the function operates normally according to the following conditions:

Monitor item	Condition		Value
TILT PULSE	Steering column	Operate (UP-WARD)	Change (decrease)
		Operate (DOWN-WARD)	Change (increase)
		Release	No change

Is the inspection result normal?

- YES >> Inspection End.  
 NO >> Perform diagnosis procedure. Refer to [ADP-103, "Diagnosis Procedure"](#).

### Diagnosis Procedure

INFOID:000000012246539

Regarding Wiring Diagram information, refer to [ADP-38, "Wiring Diagram"](#).

#### 1. CHECK TILT SENSOR SIGNAL

1. Turn ignition switch ON.
2. Check voltage signal between driver seat control unit connector and ground with oscilloscope.

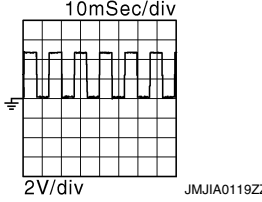
(+)		(-)	Condition	Voltage (V) (Approx.)
Driver seat control unit Connector	Terminal			
B222	28	Ground	Steering column Operate	
			Other than above	0 or 5

Is the inspection result normal?

- YES >> Replace driver seat control unit. Refer to [ADP-130, "Removal and Installation"](#).  
 NO >> GO TO 2.

#### 2. CHECK TILT SENSOR CIRCUIT

1. Turn ignition switch OFF.
2. Disconnect driver seat control unit and tilt motor.
3. Check continuity between driver seat control unit harness connector and tilt motor harness connector.

Driver seat control unit		Tilt motor		Continuity
Connector	Terminal	Connector	Terminal	
B222	28	M71	5	Yes

4. Check continuity between driver seat control unit harness connector and ground.

# TILT SENSOR

## < DTC/CIRCUIT DIAGNOSIS >

Driver seat control unit		Ground	Continuity
Connector	Terminal		
B222	28		No

Is the inspection result normal?

YES >> GO TO 3.

NO >> Repair or replace harness.

### 3. CHECK TILT SENSOR POWER SUPPLY

1. Connect driver seat control unit.
2. Turn ignition switch ON.
3. Check voltage between tilt motor harness connector and ground.

Tilt motor		Ground	Voltage (V) (Approx.)
Connector	Terminal		
M71	4		Battery voltage

Is the inspection result normal?

YES >> GO TO 5.

NO >> GO TO 4.

### 4. CHECK TILT SENSOR POWER SUPPLY CIRCUIT

1. Turn ignition switch OFF.
2. Disconnect automatic drive positioner control unit.
3. Check continuity between automatic drive positioner control unit harness connector and tilt motor harness connector.

Automatic drive positioner control unit		Tilt motor		Continuity
Connector	Terminal	Connector	Terminal	
M67	27	M71	4	Yes

4. Check continuity between automatic drive positioner control unit harness connector and ground.

Automatic drive positioner control unit		Ground	Continuity
Connector	Terminal		
M67	27		No

Is the inspection result normal?

YES >> Replace automatic drive positioner control unit. Refer to [ADP-131, "Removal and Installation"](#).

NO >> Repair or replace harness or connector.

### 5. CHECK TILT SENSOR GROUND CIRCUIT

1. Turn ignition switch OFF.
2. Disconnect automatic drive positioner control unit.
3. Check continuity between automatic drive positioner control unit harness connector and tilt motor harness connector.

Automatic drive positioner control unit		Tilt motor		Continuity
Connector	Terminal	Connector	Terminal	
M63	20	M71	6	Yes

Is the inspection result normal?

YES >> Replace tilt motor. Refer to [SE-79, "Removal and Installation"](#).

NO >> Repair or replace harness.



# TELESCOPIC SENSOR

< DTC/CIRCUIT DIAGNOSIS >

## TELESCOPIC SENSOR

### Component Function Check

INFOID:000000012246540

#### 1. DATA MONITOR

##### CONSULT

1. Select "Data Monitor" mode of "AUTO DRIVE POS."
2. Select "TELESCO PULSE".
3. Check that the function operates normally according to the following conditions:

Monitor item	Condition		Value
TELESCO PULSE	Steering column	Operate (forward)	Change (decrease)
		Operate (backward)	Change (increase)
		Release	No change

Is the inspection result normal?

- YES >> Inspection End.  
 NO >> Perform diagnosis procedure. Refer to [ADP-105, "Diagnosis Procedure"](#).

### Diagnosis Procedure

INFOID:000000012246541

Regarding Wiring Diagram information, refer to [ADP-38, "Wiring Diagram"](#).

#### 1. CHECK TELESCOPIC SENSOR SIGNAL

1. Turn ignition switch ON.
2. Check voltage signal between driver seat control unit connector and ground with oscilloscope.

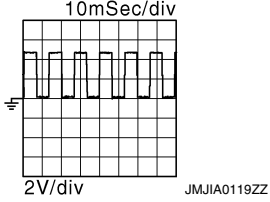
(+)		(-)	Condition	Voltage (V) (Approx.)
Driver seat control unit Connector	Terminal			
B222	12	Ground	Steering column Operate	
			Other than above	0 or 5

Is the inspection result normal?

- YES >> Replace driver seat control unit. Refer to [ADP-130, "Removal and Installation"](#).  
 NO >> GO TO 2.

#### 2. CHECK TELESCOPIC SENSOR CIRCUIT

1. Turn ignition switch OFF.
2. Disconnect driver seat control unit and telescopic motor.
3. Check continuity between driver seat control unit harness connector and telescopic motor harness connector.

Driver seat control unit		Telescopic motor		Continuity
Connector	Terminal	Connector	Terminal	
B222	12	M73	4	Yes

A  
B  
C  
D  
E  
F  
G  
H  
I  
K  
L  
M  
N  
O  
P

ADP

# TELESCOPIC SENSOR

## < DTC/CIRCUIT DIAGNOSIS >

4. Check continuity between driver seat control unit harness connector and ground.

Driver seat control unit		Ground	Continuity
Connector	Terminal		
B222	12		No

### Is the inspection result normal?

- YES >> GO TO 3.  
 NO >> Repair or replace harness.

## 3. CHECK TELESCOPIC SENSOR POWER SUPPLY

1. Connect driver seat control unit.
2. Turn ignition switch ON.
3. Check voltage between telescopic motor harness connector and ground.

Telescopic motor		Ground	Voltage (V) (Approx.)
Connector	Terminal		
M73	5	Ground	Battery voltage

### Is the inspection result normal?

- YES >> GO TO 5.  
 NO >> GO TO 4.

## 4. CHECK TELESCOPIC SENSOR POWER SUPPLY CIRCUIT

1. Turn ignition switch OFF.
2. Disconnect automatic drive positioner control unit.
3. Check continuity between automatic drive positioner control unit harness connector and telescopic motor harness connector.

Automatic drive positioner control unit		Telescopic motor		Continuity
Connector	Terminal	Connector	Terminal	
M67	27	M73	5	Yes

4. Check continuity between automatic drive positioner control unit harness connector and ground.

Automatic drive positioner control unit		Ground	Continuity
Connector	Terminal		
M67	27		No

### Is the inspection result normal?

- YES >> Replace automatic drive positioner control unit. Refer to [ADP-131, "Removal and Installation"](#).  
 NO >> Repair or replace harness.

## 5. CHECK TELESCOPIC SENSOR GROUND CIRCUIT

1. Turn ignition switch OFF.
2. Disconnect automatic drive positioner control unit.
3. Check continuity between automatic drive positioner control unit harness connector and telescopic motor harness connector.

Automatic drive positioner control unit		Telescopic motor		Continuity
Connector	Terminal	Connector	Terminal	
M63	20	M73	3	Yes

### Is the inspection result normal?

- YES >> Replace telescopic motor. Refer to [ST-32, "Exploded View"](#).  
 NO >> Repair or replace harness.

# MIRROR SENSOR

< DTC/CIRCUIT DIAGNOSIS >

## MIRROR SENSOR DRIVER SIDE

### DRIVER SIDE : Component Function Check

INFOID:0000000012246542

#### 1. DATA MONITOR

##### ⓂCONSULT

1. Select "Data Monitor" mode of "AUTO DRIVE POS."
2. Select "MIR/SEN LH U-D", "MIR/SEN LH R-L".
3. Check that the function operates normally according to the following conditions:

Monitor item	Condition		Value
MIR/SEN LH U-D	Door mirror LH	Close to peak	3.4V
		Close to valley	0.6V
MIR/SEN LH R-L		Close to right edge	3.4V
		Close to left edge	0.6V

Is the inspection result normal?

YES >> Inspection End.

NO >> Perform diagnosis procedure. Refer to [ADP-107. "DRIVER SIDE : Diagnosis Procedure"](#).

### DRIVER SIDE : Diagnosis Procedure

INFOID:0000000012246543

Regarding Wiring Diagram information, refer to [ADP-38. "Wiring Diagram"](#).

#### 1. CHECK DOOR MIRROR LH SENSOR SIGNAL

1. Turn ignition switch to ACC.
2. Check voltage between door mirror LH harness connector and ground.

(+) Door mirror LH		(-)	Condition	Voltage (V) (Approx.)	
Connector	Terminal				
D12	24	Ground	Door mirror LH	Close to peak	3.4
				Close to valley	0.6
	23			Close to right edge	3.4
				Close to left edge	0.6

Is the inspection result normal?

YES >> GO TO 5.

NO >> GO TO 2.

#### 2. CHECK DOOR MIRROR LH SENSOR CIRCUIT 1

1. Turn ignition switch OFF.
2. Disconnect automatic drive positioner control unit and door mirror LH connector.
3. Check continuity between automatic drive positioner control unit harness connector and door mirror LH harness connector.

Automatic drive positioner control unit		Door mirror LH		Continuity
Connector	Terminal	Connector	Terminal	
M63	6	D4	24	Yes
	18		23	

# MIRROR SENSOR

## < DTC/CIRCUIT DIAGNOSIS >

4. Check continuity between automatic drive positioner control unit harness connector and ground.

Automatic drive positioner control unit		Ground	Continuity
Connector	Terminal		No
M63	6		
	18		

### Is the inspection result normal?

- YES >> GO TO 3.  
 NO >> Repair or replace harness.

## 3. CHECK DOOR MIRROR LH SENSOR CIRCUIT 2

1. Check continuity between automatic drive positioner control unit harness connector and door mirror LH harness connector.

Automatic drive positioner control unit		Door mirror LH		Continuity
Connector	Terminal	Connector	Terminal	
M63	20	D12	21	Yes
	21		22	

2. Check continuity between automatic drive positioner control unit harness connector and ground.

Automatic drive positioner control unit		Ground	Continuity
Connector	Terminal		No
M63	20		
	21		

### Is the inspection result normal?

- YES >> GO TO 4.  
 NO >> Repair or replace harness.

## 4. CHECK TILT MOTOR ADJUSTING OPERATION

1. Connect automatic drive positioner control unit and door mirror LH.
2. Turn ignition switch ON.
3. Check tilt motor adjusting operation with memory function.

### Is the operation normal?

- YES >> Replace door mirror actuator (built into door mirror LH). Refer to [MIR-25, "Removal and Installation"](#).  
 NO >> Replace automatic drive positioner control unit. Refer to [ADP-131, "Removal and Installation"](#).

## 5. CHECK INTERMITTENT INCIDENT

Refer to [GI-41, "Intermittent Incident"](#).

### Is the inspection result normal?

- YES >> Replace automatic drive positioner control unit. Refer to [ADP-131, "Removal and Installation"](#).  
 NO >> Repair or replace the malfunctioning part.

## PASSENGER SIDE

### PASSENGER SIDE : Component Function Check

INFOID:000000012246544

## 1. CHECK FUNCTION

### CONSULT

1. Select "Data Monitor" mode of "AUTO DRIVE POS."
2. Select "MIR/SEN RH U-D", "MIR/SEN RH R-L".
3. Check that the function operates normally according to the following conditions:

# MIRROR SENSOR

## < DTC/CIRCUIT DIAGNOSIS >

Monitor item	Condition	Value
MIR/SEN RH U-D	Close to peak	3.4V
	Close to valley	0.6V
MIR/SEN RH R-L	Close to right edge	3.4V
	Close to left edge	0.6V

Is the inspection result normal?

YES >> Inspection End.

NO >> Perform diagnosis procedure. Refer to [ADP-109. "PASSENGER SIDE : Diagnosis Procedure"](#).

## PASSENGER SIDE : Diagnosis Procedure

INFOID:000000012246545

Regarding Wiring Diagram information, refer to [ADP-38. "Wiring Diagram"](#).

### 1. CHECK DOOR MIRROR RH SENSOR SIGNAL

- Turn ignition switch to ACC.
- Check voltage between door mirror RH harness connector and ground.

(+)		(-)	Condition	Voltage (V) (Approx.)	
Door mirror RH					
Connector	Terminal				
D114	24	Ground	Door mirror RH	Close to peak	3.4
				Close to valley	0.6
	23			Close to right edge	3.4
				Close to left edge	0.6

Is the inspection result normal?

YES >> GO TO 5.

NO >> GO TO 2.

### 2. CHECK DOOR MIRROR RH SENSOR CIRCUIT 1

- Turn ignition switch OFF.
- Disconnect automatic drive positioner control unit and door mirror RH.
- Check continuity between automatic drive positioner control unit harness connector and door mirror RH harness connector.

Automatic drive positioner control unit		Door mirror RH		Continuity
Connector	Terminal	Connector	Terminal	
M63	5	D114	24	Yes
	17		23	

- Check continuity between automatic drive positioner control unit harness connector and ground.

Automatic drive positioner control unit		Ground	Continuity
Connector	Terminal		
M63	5		No
	17		

Is the inspection result normal?

YES >> GO TO 3.

NO >> Repair or replace harness.

# MIRROR SENSOR

< DTC/CIRCUIT DIAGNOSIS >

## 3. CHECK DOOR MIRROR RH SENSOR CIRCUIT 2

1. Check continuity between automatic drive positioner control unit harness connector and door mirror RH harness connector.

Automatic drive positioner control unit		Door mirror LH		Continuity
Connector	Terminal	Connector	Terminal	
M63	20	D114	21	Yes
	21		22	

2. Check continuity between automatic drive positioner control unit harness connector and ground.

Automatic drive positioner control unit		Ground	Continuity
Connector	Terminal		
M63	20		No
	21		

Is the inspection result normal?

YES >> GO TO 4.

NO >> Repair or replace harness.

## 4. CHECK TILT MOTOR ADJUSTING OPERATION

1. Connect automatic drive positioner control unit and door mirror RH.
2. Turn ignition switch ON.
3. Check tilt motor adjusting operation with memory function.

Is the operation normal?

YES >> Replace door mirror actuator (built into door mirror RH). Refer to [MIR-25, "Removal and Installation"](#).

NO >> Replace automatic drive positioner control unit. Refer to [ADP-131, "Removal and Installation"](#).

## 5. CHECK INTERMITTENT INCIDENT

Refer to [GI-41, "Intermittent Incident"](#).

Is the inspection result normal?

YES >> Replace automatic drive positioner control unit. Refer to [ADP-131, "Removal and Installation"](#).

NO >> Repair or replace the malfunctioning part.

# SLIDING MOTOR

< DTC/CIRCUIT DIAGNOSIS >

## SLIDING MOTOR

### Component Function Check

INFOID:000000012246546

#### 1. ACTIVE TEST

##### CONSULT

1. Select "Active Test" mode of "AUTO DRIVE POS."
2. Select "SEAT SLIDE".
3. Check that the function operates normally.

Test Item		Description	
SEAT SLIDE	OFF	Seat sliding	Stop
	FR		Forward
	RR		Backward

Is the operation of relevant parts normal?

YES >> Inspection End.

NO >> Perform diagnosis procedure. Refer to [ADP-111, "Diagnosis Procedure"](#).

### Diagnosis Procedure

INFOID:000000012246547

Regarding Wiring Diagram information, refer to [ADP-38, "Wiring Diagram"](#).

#### 1. CHECK SLIDING MOTOR LH POWER SUPPLY

##### CONSULT

1. Turn the ignition switch to ACC.
2. Perform "SEAT SLIDE" in "Active Test" mode of "AUTO DRIVE POS."
3. Check voltage between driver seat control unit harness connector and ground.

ADP

(+)		(-)	Condition	Voltage (V) (Approx.)	
Driver seat control unit Connector	Terminal				
B223	36	Ground	SEAT SLIDE	OFF	0
				FR (forward)	0
				RR (backward)	Battery voltage
	44			OFF	0
				FR (forward)	Battery voltage
				RR (backward)	0

Is the inspection result normal?

YES >> Replace sliding motor LH. Refer to [SE-79, "Removal and Installation"](#).

NO >> GO TO 2.

#### 2. CHECK SLIDING MOTOR LH CIRCUIT

1. Turn ignition switch OFF.
2. Disconnect driver seat control unit and sliding motor LH.
3. Check continuity between driver seat control unit harness connector and sliding motor LH harness connector.

# SLIDING MOTOR

## < DTC/CIRCUIT DIAGNOSIS >

Driver seat control unit		Sliding motor LH		Continuity
Connector	Terminal	Connector	Terminal	
B223	36	B226	4	Yes
	44		6	

4. Check continuity between driver seat control unit harness connector and ground.

Driver seat control unit connector		Ground	Continuity
Connector	Terminal		
B223	36		No
	44		

Is the inspection result normal?

YES >> GO TO 3.

NO >> Repair or replace harness.

### 3. CHECK INTERMITTENT INCIDENT

Refer to [GI-41, "Intermittent Incident"](#).

Is the inspection result normal?

YES >> Replace driver seat control unit. Refer to [ADP-130, "Removal and Installation"](#).

NO >> Repair or replace the malfunctioning part.



# RECLINING MOTOR

< DTC/CIRCUIT DIAGNOSIS >

## RECLINING MOTOR

### Component Function Check

INFOID:000000012246548

#### 1. ACTIVE TEST

##### CONSULT

1. Select "Active Test" mode of "AUTO DRIVE POS."
2. Select "SEAT RECLINING".
3. Check that the function operates normally.

Test Item		Description	
SEAT RECLINING	OFF	Seat reclining	Stop
	FR		Forward
	RR		Backward

Is the operation of relevant parts normal?

YES >> Inspection End.

NO >> Perform diagnosis procedure. Refer to [ADP-113, "Diagnosis Procedure"](#).

### Diagnosis Procedure

INFOID:000000012246549

Regarding Wiring Diagram information, refer to [ADP-38, "Wiring Diagram"](#).

#### 1. CHECK RECLINING MOTOR LH POWER SUPPLY

##### CONSULT

1. Turn the ignition switch to ACC.
2. Perform "SEAT RECLINING" in "Active Test" mode of "AUTO DRIVE POS."
3. Check voltage between driver seat control unit harness connector and ground.

ADP

(+)		(-)	Condition	Voltage (V) (Approx.)	
Driver seat control unit Connector	Terminal				
B223	35	Ground	SEAT RECLINING	OFF	0
			FR (forward)	0	
			RR (backward)	Battery voltage	
	43		SEAT RECLINING	OFF	0
			FR (forward)	Battery voltage	
			RR (backward)	0	

Is the inspection result normal?

YES >> Replace reclining motor LH. Refer to [SE-79, "Removal and Installation"](#).

NO >> GO TO 2.

#### 2. CHECK RECLINING MOTOR LH CIRCUIT

1. Turn ignition switch OFF.
2. Disconnect driver seat control unit and reclining motor LH.
3. Check continuity between driver seat control unit harness connector and reclining motor LH harness connector.

## RECLINING MOTOR

### < DTC/CIRCUIT DIAGNOSIS >

Driver seat control unit		Reclining motor LH		Continuity
Connector	Terminal	Connector	Terminal	
B223	35	B225	4	Yes
	43		6	

4. Check continuity between driver seat control unit harness connector and ground.

Driver seat control unit		Ground	Continuity
Connector	Terminal		
B223	35		No
	43		

Is the inspection result normal?

YES >> GO TO 3.

NO >> Repair or replace harness.

### 3. CHECK INTERMITTENT INCIDENT

Refer to [GI-41, "Intermittent Incident"](#).

Is the inspection result normal?

YES >> Replace driver seat control unit. Refer to [ADP-130, "Removal and Installation"](#).

NO >> Repair or replace the malfunctioning part.

# LIFTING MOTOR (FRONT)

< DTC/CIRCUIT DIAGNOSIS >

## LIFTING MOTOR (FRONT)

### Component Function Check

INFOID:000000012246550

#### 1. ACTIVE TEST

##### CONSULT

1. Select "Active Test" mode of "AUTO DRIVE POS".
2. Select "SEAT LIFTER FR".
3. Check that the function operates normally.

Test Item		Description	
SEAT LIFTER FR	OFF	Seat lifting (front)	Stop
	UP		Upward
	DWN		Downward

Is the operation of relevant parts normal?

- YES >> Inspection End.  
 NO >> Perform diagnosis procedure. Refer to [ADP-115, "Diagnosis Procedure"](#).

### Diagnosis Procedure

INFOID:000000012246551

Regarding Wiring Diagram information, refer to [ADP-38, "Wiring Diagram"](#).

#### 1. CHECK LIFTING MOTOR LH (FRONT) POWER SUPPLY

##### CONSULT

1. Turn the ignition switch to ACC.
2. Perform "SEAT LIFTER FR" in "Active Test" mode of "AUTO DRIVE POS".
3. Check voltage between driver seat control unit harness connector and ground.

ADP

(+)		(-)	Condition	Voltage (V) (Approx.)	
Driver seat control unit					
Connector	Terminal				
B223	34	Ground	SEAT LIFTER FR	OFF	0
				UP	0
				DWN (down)	Battery voltage
	42			OFF	0
				UP	Battery voltage
				DWN (down)	0

Is the inspection result normal?

- YES >> Replace lifting motor LH (front). Refer to [SE-79, "Removal and Installation"](#).  
 NO >> GO TO 2.

#### 2. CHECK LIFTING MOTOR LH (FRONT) CIRCUIT

1. Turn ignition switch OFF.
2. Disconnect driver seat control unit and lifting motor LH (front).
3. Check continuity between driver seat control unit harness connector and lifting motor LH (front) harness connector.

## LIFTING MOTOR (FRONT)

### < DTC/CIRCUIT DIAGNOSIS >

Driver seat control unit		Lifting motor LH (front)		Continuity
Connector	Terminal	Connector	Terminal	
B223	34	B227	4	Yes
	42		6	

4. Check continuity between driver seat control unit harness connector and ground.

Driver seat control unit		Ground	Continuity
Connector	Terminal		
B223	34		No
	42		

Is the inspection result normal?

YES >> GO TO 3.

NO >> Repair or replace harness.

### 3. CHECK INTERMITTENT INCIDENT

Refer to [GI-41, "Intermittent Incident"](#).

Is the inspection result normal?

YES >> Replace driver seat control unit. Refer to [ADP-130, "Removal and Installation"](#).

NO >> Repair or replace the malfunctioning part.

# LIFTING MOTOR (REAR)

< DTC/CIRCUIT DIAGNOSIS >

## LIFTING MOTOR (REAR)

### Component Function Check

INFOID:000000012246552

#### 1. ACTIVE TEST

##### CONSULT

1. Select "Active Test" mode of "AUTO DRIVE POS."
2. Select "SEAT LIFTER RR".
3. Check that the function operates normally.

Test Item		Description	
SEAT LIFTER RR	OFF	Seat lifting (rear)	Stop
	UP		Upward
	DWN		Downward

Is the operation of relevant parts normal?

- YES >> Inspection End.  
 NO >> Perform diagnosis procedure. Refer to [ADP-117, "Diagnosis Procedure"](#).

### Diagnosis Procedure

INFOID:000000012246553

Regarding Wiring Diagram information, refer to [ADP-38, "Wiring Diagram"](#).

#### 1. CHECK LIFTING MOTOR LH (REAR) POWER SUPPLY

##### CONSULT

1. Turn the ignition switch to ACC.
2. Perform "SEAT LIFTER RR" in "Active Test" mode of "AUTO DRIVE POS."
3. Check voltage between driver seat control unit harness connector and ground.

ADP

(+)		(-)	Condition	Voltage (V) (Approx.)	
Driver seat control unit					
Connector	Terminal				
B223	40	Ground	SEAT LIFTER RR	OFF	0
				UP	0
				DWN (down)	Battery voltage
	41			OFF	0
				UP	Battery voltage
				DWN (down)	0

Is the inspection result normal?

- YES >> Replace lifting motor LH (rear). Refer to [SE-79, "Removal and Installation"](#).  
 NO >> GO TO 2.

#### 2. CHECK LIFTING MOTOR (REAR) CIRCUIT

1. Turn ignition switch OFF.
2. Disconnect driver seat control unit and lifting motor LH (rear).
3. Check continuity between driver seat control unit harness connector and lifting motor LH (rear) harness connector.

## LIFTING MOTOR (REAR)

### < DTC/CIRCUIT DIAGNOSIS >

Driver seat control unit		Lifting motor LH (rear)		Continuity
Connector	Terminal	Connector	Terminal	
B223	41	B228	6	Yes
	40		4	

4. Check continuity between driver seat control unit harness connector and ground.

Driver seat control unit		Ground	Continuity
Connector	Terminal		
B223	41		No
	40		

Is the inspection result normal?

YES >> GO TO 3.

NO >> Repair or replace harness.

### 3. CHECK INTERMITTENT INCIDENT

Refer to [GI-41, "Intermittent Incident"](#).

Is the inspection result normal?

YES >> Replace driver seat control unit. Refer to [ADP-130, "Removal and Installation"](#).

NO >> Repair or replace the malfunctioning part.

# TILT MOTOR

< DTC/CIRCUIT DIAGNOSIS >

## TILT MOTOR

### Component Function Check

INFOID:000000012246554

#### 1. ACTIVE TEST

##### CONSULT

1. Select "Active Test" mode of "AUTO DRIVE POS."
2. Select "TILT MOTOR".
3. Check that the function operates normally.

Test item		Description	
TILT MOTOR	OFF	Steering tilt	Stop
	UP		Upward
	DWN		Downward

Is the operation of relevant parts normal?

- YES >> Inspection End.  
 NO >> Perform diagnosis procedure. Refer to [ADP-119, "Diagnosis Procedure"](#).

### Diagnosis Procedure

INFOID:000000012246555

Regarding Wiring Diagram information, refer to [ADP-38, "Wiring Diagram"](#).

#### 1. CHECK TILT MOTOR POWER SUPPLY

##### CONSULT

1. Turn ignition switch OFF.
2. Disconnect tilt motor.
3. Turn the ignition switch ON.
4. Select "TILT MOTOR" in "Active Test" mode of "AUTO DRIVE POS".
5. Check voltage between tilt motor harness connector and ground.

(+)		(-)	Condition	Voltage (V) (Approx.)	
Tilt motor					
Connector	Terminal				
M71	1	Ground	TILT MOTOR	OFF	0
				UP	0
				DWN (down)	Battery voltage
	2			OFF	0
				UP	Battery voltage
				DWN (down)	0

Is the inspection result normal?

- YES >> Replace tilt motor. Refer to [SE-79, "Removal and Installation"](#).  
 NO >> GO TO 2.

#### 2. CHECK TILT MOTOR CIRCUIT

1. Turn ignition switch OFF.
2. Disconnect automatic drive positioner control unit.
3. Check continuity between automatic drive positioner control unit harness connector and tilt motor harness connector.

A  
B  
C  
D  
E  
F  
G  
H  
I  
K  
L  
M  
N  
O  
P

ADP

# TILT MOTOR

## < DTC/CIRCUIT DIAGNOSIS >

Automatic drive positioner control unit		Tilt motor		Continuity
Connector	Terminal	Connector	Terminal	
M67	28	M85	1	Yes
	29		2	

4. Check continuity between automatic drive positioner control unit harness connector and ground.

Automatic drive positioner control unit		Ground	Continuity
Connector	Terminal		
M67	28		No
	29		

Is the inspection result normal?

- YES >> Replace automatic drive positioner control unit. Refer to [ADP-131, "Removal and Installation"](#).  
 NO >> Repair or replace harness.



# TELESCOPIC MOTOR

< DTC/CIRCUIT DIAGNOSIS >

## TELESCOPIC MOTOR

### Component Function Check

INFOID:000000012246556

#### 1. ACTIVE TEST

##### CONSULT

1. Select "Active Test" mode of "AUTO DRIVE POS."
2. Select "TELESCO MOTOR".
3. Check that the function operates normally.

Test item		Description	
TELESCO MOTOR	OFF	Steering telescopic	Stop
	FR		Forward
	RR		Backward

Is the operation of relevant parts normal?

YES >> Inspection End.

NO >> Perform diagnosis procedure. Refer to [ADP-121, "Diagnosis Procedure"](#).

### Diagnosis Procedure

INFOID:000000012246557

Regarding Wiring Diagram information, refer to [ADP-38, "Wiring Diagram"](#).

#### 1. CHECK TELESCOPIC MOTOR POWER SUPPLY

##### CONSULT

1. Turn ignition switch OFF.
2. Disconnect telescopic motor.
3. Turn the ignition switch ON.
4. Perform "TELESCO MOTOR" in "Active Test" mode of "AUTO DRIVE POS".
5. Check voltage between telescopic motor harness connector and ground.

(+)		(-)	Condition	Voltage (V) (Approx.)	
Connector	Terminal				
M73	2	Ground	TELESCOPIC MOTOR	OFF	0
			FR (forward)	0	
			RR (backward)	Battery voltage	
	1		TELESCOPIC MOTOR	OFF	0
			FR (forward)	Battery voltage	
			RR (backward)	0	

Is the inspection result normal?

YES >> Replace telescopic motor. Refer to [ST-32, "Exploded View"](#).

NO >> GO TO 2.

#### 2. CHECK TELESCOPIC MOTOR CIRCUIT

1. Turn ignition switch OFF.
2. Disconnect automatic drive positioner control unit.
3. Check continuity between automatic drive positioner control unit harness connector and telescopic motor harness connector.

## TELESCOPIC MOTOR

### < DTC/CIRCUIT DIAGNOSIS >

Automatic drive positioner control unit		Telescopic motor		Continuity
Connector	Terminal	Connector	Terminal	
M67	29	M73	1	Yes
	26		2	

4. Check continuity between automatic drive positioner control unit harness connector and ground.

Automatic drive positioner control unit		Ground	Continuity
Connector	Terminal		
M67	29		No
	26		

**Is the inspection result normal?**

- YES >> Replace automatic drive positioner control unit. Refer to [ADP-131, "Removal and Installation"](#).
- NO >> Repair or replace harness.

# DOOR MIRROR MOTOR

< DTC/CIRCUIT DIAGNOSIS >

## DOOR MIRROR MOTOR

### Component Function Check

INFOID:000000012246558

#### 1. ACTIVE TEST

##### CONSULT

1. Select "Active Test" mode of "AUTO DRIVE POS."
2. Select "MIRROR MOTOR RH" and "MIRROR MOTOR LH".
3. Check that the function operates normally.

Test item		Description	
MIRROR MOTOR LH	UP	Door mirror (driver side)	Upward
	DN		Downward
	LH		Leftward
	RH		Rightward
	OFF		Stop
MIRROR MOTOR RH	UP	Door mirror (passenger side)	Upward
	DN		Downward
	LH		Leftward
	RH		Rightward
	OFF		Stop

Is the inspection result normal?

- YES >> Door mirror motor function is OK.  
 NO >> Refer to [ADP-123, "Diagnosis Procedure"](#).

### Diagnosis Procedure

INFOID:000000012246559

Regarding Wiring Diagram information, refer to [ADP-38, "Wiring Diagram"](#).

#### 1. CHECK DOOR MIRROR MOTOR INPUT SIGNAL

1. Turn ignition switch ON.
2. Check voltage between door mirror connector and ground.

(+)		(-)	Door mirror remote control switch condition	Voltage (V) (Approx.)
Door mirror				
Connector	Terminal			
D12 (LH) D114 (RH)	12	Ground	UP	Battery voltage
			Other than above	0
	10		LEFT	Battery voltage
			Other than above	0
	11		DOWN / RIGHT	Battery voltage
			Other than above	0

Is the inspection result normal?

- YES >> Refer to [ADP-125, "Component Inspection"](#).  
 NO >> GO TO 2.

#### 2. CHECK HARNESS CONTINUITY

1. Turn ignition switch OFF.
2. Disconnect automatic drive positioner control unit and door mirror.

A  
B  
C  
D  
E  
F  
G  
H  
I  
K  
L  
M  
N  
O  
P

ADP

# DOOR MIRROR MOTOR

## < DTC/CIRCUIT DIAGNOSIS >

3. Check continuity between automatic drive positioner control unit connector and door mirror connector.

Door mirror LH

Automatic drive positioner control unit		Door mirror LH		Continuity
Connector	Terminal	Connector	Terminal	
M63	12	D12	10	Yes
	23		12	
	24		11	

Door mirror RH

Automatic drive positioner control unit		Door mirror RH		Continuity
Connector	Terminal	Connector	Terminal	
M63	10	D114	12	Yes
	11		11	
	22		10	

4. Check continuity between automatic drive positioner control unit connector and ground.

Door mirror LH

Automatic drive positioner control unit		Ground	Continuity
Connector	Terminal		
M63	12	Ground	No
	23		
	24		

Door mirror RH

Automatic drive positioner control unit		Ground	Continuity
Connector	Terminal		
M63	10	Ground	No
	11		
	22		

Is the inspection result normal?

YES >> GO TO 3.

NO >> Repair or replace harness.

### 3. CHECK AUTOMATIC DRIVE POSITIONER CONTROL UNIT OUTPUT SIGNAL

1. Connect automatic drive positioner control unit.
2. Turn ignition switch ON.
3. Check voltage between automatic drive positioner control unit connector and ground.

Door mirror LH

(+)		(-)	Mirror switch condition	Voltage (V) (Approx.)
Automatic drive positioner control unit				
Connector	Terminal			
M63	12	Ground	DOWN / RIGHT	Battery voltage
			Other than above	0
	23		UP	Battery voltage
			Other than above	0
	24		LEFT	Battery voltage
			Other than above	0

# DOOR MIRROR MOTOR

## < DTC/CIRCUIT DIAGNOSIS >

Door mirror RH

(+)		(-)	Mirror switch condition	Voltage (V) (Approx.)
Automatic drive positioner control unit				
Connector	Terminal			
M63	10	Ground	UP	Battery voltage
			Other than above	0
	11		LEFT	Battery voltage
			Other than above	0
	22		DOWN / RIGHT	Battery voltage
			Other than above	0

Is the inspection result normal?

YES >> GO TO 4.

NO >> Replace automatic drive positioner control unit. Refer to [ADP-131, "Removal and Installation"](#).

### 4. CHECK DOOR MIRROR MOTOR

Check door mirror motor.

Refer to [ADP-125, "Component Inspection"](#).

Is the inspection result normal?

YES >> Refer to [GI-41, "Intermittent Incident"](#).

NO >> Replace door mirror actuator. Refer to [MIR-25, "Removal and Installation"](#).

### Component Inspection

INFOID:0000000012246560

#### 1. CHECK DOOR MIRROR MOTOR-I

Check that door mirror motor does not trap foreign objects and does not have any damage.

Refer to [MIR-21, "Exploded View"](#).

Is the inspection result normal?

YES >> GO TO 2.

NO >> Replace door mirror actuator. Refer to [MIR-25, "Removal and Installation"](#).

#### 2. CHECK DOOR MIRROR MOTOR-II

1. Turn ignition switch OFF.
2. Disconnect door mirror.
3. Apply 12V to each power supply terminal of door mirror motor.

Door mirror connector	Terminal		Operational direction
	(+)	(-)	
D12 (LH) D114 (RH)	10	11	RIGHT
	11	10	LEFT
	12	10	UP
	10	12	DOWN

Is the inspection result normal?

YES >> Inspection End.

NO >> Replace door mirror actuator. Refer to [MIR-25, "Removal and Installation"](#).

# SEAT MEMORY INDICATOR

< DTC/CIRCUIT DIAGNOSIS >

## SEAT MEMORY INDICATOR

### Component Function Check

INFOID:000000012246561

#### 1. ACTIVE TEST

##### CONSULT

1. Select "Active Test" mode of "AUTO DRIVE POS."
2. Select "MEMORY SW INDCTR".
3. Check that the function operates normally.

Test item		Description	
MEMORY SW INDCTR	OFF	Memory switch indicator	OFF
	ON-1		Indicator 1: ON
	ON-2		Indicator 2: ON

Is the operation of relevant parts normal?

YES >> Inspection End.

NO >> Perform diagnosis procedure. Refer to [ADP-126, "Diagnosis Procedure"](#).

### Diagnosis Procedure

INFOID:000000012246562

Regarding Wiring Diagram information, refer to [ADP-38, "Wiring Diagram"](#).

#### 1. CHECK SEAT MEMORY INDICATOR CIRCUIT

1. Turn ignition switch OFF.
2. Disconnect driver seat control unit and seat memory switch.
3. Check continuity between driver seat control unit harness connector and seat memory switch harness connector.

Driver seat control unit		Seat memory switch		Continuity
Connector	Terminal	Connector	Terminal	
B222	10	D13	12	Yes
	26		11	

4. Check continuity between driver seat control unit harness connector and ground.

Driver seat control unit		Ground	Continuity
Connector	Terminal		
B222	10		No
	26		

Is the inspection result normal?

YES >> GO TO 2.

NO >> Repair or replace harness.

#### 2. CHECK MEMORY INDICATOR POWER SUPPLY

Check voltage between seat memory switch harness connector and ground.

(+)		(-)	Voltage (V) (Approx.)
Seat memory switch			
Connector	Terminal	Ground	Battery voltage
D13	10		

# SEAT MEMORY INDICATOR

## < DTC/CIRCUIT DIAGNOSIS >

### Is the inspection result normal?

- YES >> GO TO 3.
- NO >> Check the following:
- 10A fuse No.9.
  - Harness for open or short between memory indicator and fuse.

### 3. CHECK MEMORY INDICATOR

Refer to [ADP-127. "Component Inspection"](#).

### Is the inspection result normal?

- YES >> GO TO 4.
- NO >> Replace seat memory switch. Refer to [ADP-132. "Removal and Installation"](#).

### 4. CHECK INTERMITTENT INCIDENT

Refer to [GI-41. "Intermittent Incident"](#).

### Is the inspection result normal?

- YES >> Replace driver seat control unit. Refer to [ADP-130. "Removal and Installation"](#).
- NO >> Repair or replace the malfunctioning part.

## Component Inspection

INFOID:000000012246563

### 1. CHECK SEAT MEMORY INDICATOR

1. Disconnect seat memory switch.
2. Check continuity between seat memory switch terminals.

Seat memory switch		Continuity
Terminal		
(+)	(-)	
10	12	Yes
	11	

### Is the inspection result normal?

- YES >> Inspection End.
- NO >> Replace seat memory switch. Refer to [ADP-132. "Removal and Installation"](#).

A  
B  
C  
D  
E  
F  
G  
H  
I  
K  
L  
M  
N  
O  
P

ADP

# ADP SYSTEM SYMPTOMS

< SYMPTOM DIAGNOSIS >

## SYMPTOM DIAGNOSIS

### ADP SYSTEM SYMPTOMS

#### Symptom Table

INFOID:000000012246564

**NOTE:**

Always perform the "Basic Inspection" before performing diagnosis in the following table. Refer to [ADP-50](#), "Work Flow".

Symptom	Diagnosis procedure	Reference page
Manual functions (for specific part) do not operate.	Sliding operation	Check sliding switch. <a href="#">ADP-72</a>
	Reclining operation	Check reclining switch. <a href="#">ADP-74</a>
	Lifting operation (front)	Check lifting switch (front). <a href="#">ADP-76</a>
	Lifting operation (rear)	Check lifting switch (rear). <a href="#">ADP-78</a>
	Tilt operation	Check tilt switch. <a href="#">ADP-80</a>
	Telescopic sensor	Check telescopic switch. <a href="#">ADP-82</a>
	Door mirror operation	1. Select switch <a href="#">ADP-87</a>
		2. Mirror switch <a href="#">ADP-89</a>
All parts of seat	Check power seat switch ground circuit. <a href="#">ADP-92</a>	
Memory functions (for specific part) do not operate.	Sliding operation	Check sliding sensor. <a href="#">ADP-94</a>
	Reclining operation	Check reclining sensor. <a href="#">ADP-96</a>
	Lifting operation (front)	Check lifting sensor (front). <a href="#">ADP-98</a>
	Lifting operation (rear)	Check lifting sensor (rear). <a href="#">ADP-101</a>
	Tilt operation	Check tilt sensor. <a href="#">ADP-103</a>
	Telescopic operation	Check telescopic sensor. <a href="#">ADP-105</a>
	Door mirror operation	Check door mirror sensor. Driver side: <a href="#">ADP-107</a> Passenger side: <a href="#">ADP-108</a>
Memory functions and manual functions (for specific part) do not operate.	Sliding operation	Check sliding motor LH. <a href="#">ADP-111</a>
	Reclining operation	Check reclining motor LH. <a href="#">ADP-113</a>
	Lifting operation (front)	Check lifting motor LH (front). <a href="#">ADP-115</a>
	Lifting operation (rear)	Check lifting motor LH (rear). <a href="#">ADP-117</a>
	Tilt operation	Check tilt motor. <a href="#">ADP-119</a>
	Telescopic operation	Check telescopic motor. <a href="#">ADP-121</a>
	Door mirror operation	Check door mirror motor. <a href="#">ADP-123</a>
Entry/Exit assist function does not operate.	1. Check system setting. <a href="#">ADP-12</a>	
	2. Perform initialization. <a href="#">ADP-54</a>	
	3. Check front door switch (driver side). <a href="#">DLK-98</a>	
Linking key fob to meter display.	1. Check door lock function. <a href="#">DLK-102</a>	
	2. Perform memory storing. <a href="#">ADP-54</a>	



# NORMAL OPERATING CONDITION

< SYMPTOM DIAGNOSIS >

## NORMAL OPERATING CONDITION

### Description

INFOID:000000012246565

The following symptoms are normal operations, and they do not indicate a malfunction.

Symptom	Cause	Action to take	Reference page
Entry/exit assist function does not operate.	No initialization has been performed.	Perform initialization.	<a href="#">ADP-54</a>
	Entry/exit assist function is disabled. <b>NOTE:</b> Entry/exit assist function is set to ON before delivery (initial setting).	Change the settings.	<a href="#">ADP-56</a>
Entry assist function does not operate.	Manual operation with power seat switch was performed after exit assist function execution.	Perform the entry assist function.	<a href="#">ADP-19</a>
Memory function, entry/exit assist function or linking a key fob to meter display function does not operate.	The operating conditions are not fulfilled.	Fulfill the operation conditions.	Memory function: <a href="#">ADP-16</a>
			Entry assist function: <a href="#">ADP-19</a>
			Exit assist function: <a href="#">ADP-18</a>
			Linking a key fob to meter display: <a href="#">ADP-21</a>

A  
B  
C  
D  
E  
F  
G  
H  
I  
K  
L  
M  
N  
O  
P

ADP

# DRIVER SEAT CONTROL UNIT

< REMOVAL AND INSTALLATION >

## REMOVAL AND INSTALLATION

### DRIVER SEAT CONTROL UNIT

#### Removal and Installation

INFOID:0000000011933328

#### REMOVAL

1. Remove driver seat. Refer to [SE-79, "Removal and Installation"](#).
2. Disconnect harness connectors (A) from driver seat control unit (1).
3. Remove screws (B) and driver seat control unit.

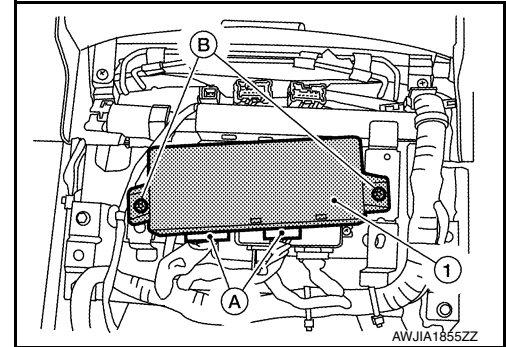

#### INSTALLATION

Installation is in the reverse order of removal.

#### NOTE:

After installing the driver seat, perform additional service when replacing control unit. Refer to [ADP-53, "ADDITIONAL SERVICE WHEN REPLACING CONTROL UNIT : Description"](#).

# AUTOMATIC DRIVE POSITIONER CONTROL UNIT

< REMOVAL AND INSTALLATION >

## AUTOMATIC DRIVE POSITIONER CONTROL UNIT

### Removal and Installation

INFOID:000000011933329

#### REMOVAL

1. Remove audio unit. Refer to [AV-183. "Removal and Installation"](#).
2. Disconnect harness connectors (B).
3. Remove automatic drive positioner control unit screw (A) and automatic drive positioner control unit (1).

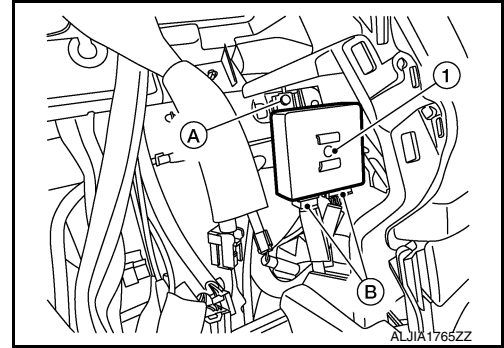

#### INSTALLATION

Installation is in the reverse order of removal.

#### NOTE:

After installing the automatic drive positioner control unit, perform additional service when replacing control unit. Refer to [ADP-53. "ADDITIONAL SERVICE WHEN REPLACING CONTROL UNIT : Description"](#).

A  
B  
C  
D  
E  
F  
G  
H  
I  
K  
L  
M  
N  
O  
P

ADP

# SEAT MEMORY SWITCH

< REMOVAL AND INSTALLATION >

## SEAT MEMORY SWITCH

### Removal and Installation

INFOID:000000011933330

#### REMOVAL

1. Remove front door finisher. Refer to [INT-27, "Removal and Installation"](#).
2. Release pawls using suitable tool and remove seat memory switch (1) from front door finisher.

 : Pawl

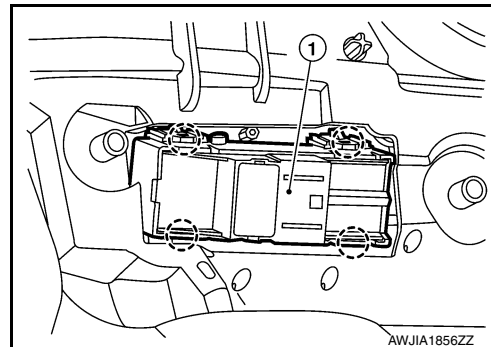

#### INSTALLATION

Installation is in the reverse order of removal.

# POWER SEAT SWITCH

< REMOVAL AND INSTALLATION >

---

## POWER SEAT SWITCH

### Removal and Installation

INFOID:000000012234400

#### REMOVAL

For the removal and installation of the power seat switch (LH), refer to [SE-84. "Power Seat Switch"](#).

A  
B  
C  
D  
E  
F  
G  
H  
I  
K  
L  
M  
N  
O  
P

ADP

# ADP STEERING SWITCH

< REMOVAL AND INSTALLATION >

## ADP STEERING SWITCH

### Removal and Installation

INFOID:000000011933331

#### REMOVAL

1. Remove steering column covers. Refer to [IP-18, "Removal and Installation - Electric steering column without paddle shifter"](#).
2. Release pawls using suitable tool and remove ADP steering switch (1) from the steering column lower cover (2).

 : Pawl

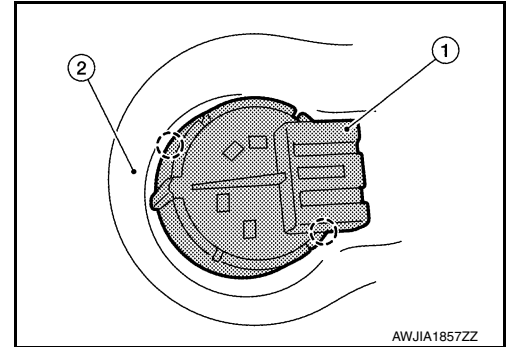

#### INSTALLATION

Installation is in the reverse order of removal.